

**Glendore Public School  
Kindergarten  
CoL WaH Lessons**



**Term 3 - Week 9**

**Name:** \_\_\_\_\_



# GLENDORE PUBLIC SCHOOL

Where Everyone can Succeed

RESPECT

CARING

LEARNING

SUCCESS



CALLAGHAN  
EDUCATION  
PATHWAYS

295 Maryland Drive, Maryland 2287  
E : [glendore-p.school@det.nsw.edu.au](mailto:glendore-p.school@det.nsw.edu.au)

P: 02 4955 6644  
F: 02 4955 6633

Web: [www.glendore-p.school.det.nsw.edu.au](http://www.glendore-p.school.det.nsw.edu.au)  
Facebook: [www.facebook.com/GlendorePSofficial/](https://www.facebook.com/GlendorePSofficial/)

## Kindergarten

### Continuity of Learning Working from Home Program (CoL WaH), Term 3 – Week 9

Key	Orange Text = Pre-recorded Lesson	Black Text= Complete Independently/under supervision
	Please open the PowerPoint for each day of the week and run in Slideshow mode to access all links and pre-recorded lessons.	

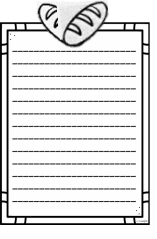
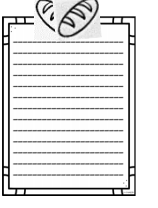
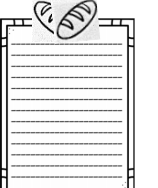
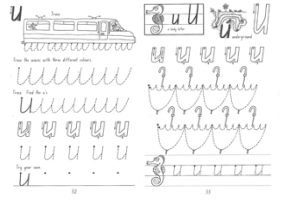
	Monday	Tuesday	Wednesday	Thursday	Friday
Morning	<p><b>Task:</b> Make your bed.</p> <p><b>English</b> <b>Task 1: Read Aloud</b> Listen to the book "From Wheat to Bread" by Leo Statts on Epic. <b>Offline Option: Brainstorm all the things you know about wheat, grains, and bread.</b></p> <p><b>Task 2: Writing (Sequencing)</b> Cut out the pictures of the steps in making bread from wheat and arrange them in the correct order.</p> 	<p><b>Task:</b> Do 20 star jumps!</p> <p><b>English</b> <b>Task 1: Read Aloud</b> Watch the pre-recorded Read Aloud about Grains. <b>Offline Option: Read the information sheet about Grains and Wheat.</b></p> <p><b>Task 2: Writing</b> Write sentences about what you have learnt about grains.</p> 	<p><b>Task:</b> Help make your lunch for today.</p> <p><b>English</b> <b>Task 1: Watch the video:</b> <a href="#">Learn about wheat with George the Farmer - YouTube</a> <b>Offline Option: Read the information sheet about Grains and Wheat.</b></p> <p><b>Task 2: Writing</b> Write an information report about wheat. Write your report on the template provided.</p> 	<p><b>Task:</b> Organise your toys today.</p> <p><b>English</b> <b>Task 1: Read Aloud</b> Watch the pre-recorded Read Aloud of <i>Nannette's Baguette</i>. <b>Offline Option: Read a book you have at home.</b></p> <p><b>Task 2: Writing</b> Write a sentence about Nannette's Baguette, (or the book you read at home) then draw a picture to go with the sentence. Can you write a second or third sentence?</p> 	<p><b>Task:</b> 20 star jumps, 15 Knee High Jog, 10 twists.</p> <p><b>English</b> <b>Task 1: Read Aloud</b> Re-watch the pre-recorded Read Aloud of <i>Nannette's Baguette</i>. <b>Offline Option: Read a book you have at home.</b></p> <p><b>Task 2: Handwriting</b> Practice writing the letter 'u' in 4 different colours OR complete the two handwriting pages in the booklet.</p> 

	<p><b>Optional Independent Activity: Handwriting Worksheet “Ll”</b></p> <p><b>Task 3: Tricky Words List</b>  <u>Practise your tricky word list in one of the following ways:</u></p> <ul style="list-style-type: none"> <li>• Rainbow writing with coloured pencils</li> <li>• Chalk</li> <li>• Play dough</li> <li>• Create using pegs or pasta</li> <li>• Letter stamps</li> </ul> <p><b>Optional Independent Activity: CVC Worksheet</b></p> <p><b>Task 4: Reading Eggs</b>  Log on and participate in Reading Eggs levels.</p> <p><b>Offline Option: Practise Jolly Phonics Sounds with the Sound Card.</b></p>	<p><b>Optional Independent Activity: Handwriting Worksheet “Tt”</b></p> <p><b>Task 3: Decodable Words</b>  Practise blending decodable words in one of the following ways:</p> <ul style="list-style-type: none"> <li>• Rainbow writing with coloured pencils</li> <li>• Chalk</li> <li>• Play dough</li> <li>• Create using pegs or pasta</li> <li>• Letter stamps</li> </ul> <p>Start with words containing 3 sounds and challenge yourself with more difficult words if you feel ready!</p> <p><b>Task 4: Phonics</b>  Follow along with the pre-recorded phonics video or if you do not have access to the PowerPoint and Videos, practise your Jolly Phonics sounds and actions using the card at the back of your work booklet.</p> <p><b>Offline Option: Practise Jolly Phonics Sounds with the Sound Card.</b></p>	<p><b>Optional Independent Activity: Handwriting Worksheet “ll”</b></p> <p><b>Task 3: Tricky Words List</b>  Practise your tricky word list in one of the following ways:</p> <ul style="list-style-type: none"> <li>• Rainbow writing with coloured pencils</li> <li>• Chalk</li> <li>• Play dough</li> <li>• Create using pegs or pasta</li> <li>• Letter stamps</li> </ul> <p><b>Option Independent Activity: CVC Worksheet</b></p> <p><b>Task 4: Reading Eggs</b>  Log on and participate in Reading Eggs levels.</p> <p><b>Offline Option: Practise Jolly Phonics Sounds with the Sound Card.</b></p>	<p><b>Optional Independent Activity: Handwriting Worksheet “Xx”</b></p> <p><b>Task 3: Decodable Words</b>  Practise blending decodable words in one of the following ways:</p> <ul style="list-style-type: none"> <li>• Rainbow writing with coloured pencils</li> <li>• Chalk</li> <li>• Play dough</li> <li>• Create using pegs or pasta</li> <li>• Letter stamps</li> </ul> <p>Start with words containing 3 sounds and challenge yourself with more difficult words if you feel ready!</p> <p><b>Optional Independent Activity: CVC Worksheet</b></p> <p><b>Task 4: Phonics</b>  Follow along with the pre-recorded phonics video or if you do not have access to the PowerPoint and Videos, practise your Jolly Phonics sounds and actions using the card at the back of your work booklet.</p> <p><b>Offline Option: Practise Jolly Phonics Sounds with the Sound Card.</b></p>	<p><b>Task 3: Tricky Words List</b>  Practise your tricky word list in one of the following ways:</p> <ul style="list-style-type: none"> <li>• Rainbow writing with coloured pencils</li> <li>• Chalk</li> <li>• Play dough</li> <li>• Create using pegs or pasta</li> <li>• Letter stamps</li> </ul> <p><b>Optional Independent Activity: CVC Worksheet</b></p> <p><b>Task 4: Reading Eggs</b>  Log on and participate in Reading Eggs levels.</p> <p><b>Offline Option: Practise Jolly Phonics Sounds with the Sound Card.</b></p>
Break	Wash your hands! Fruit Break then play outside.	Wash your hands! Fruit Break then kick a ball outside.	Wash your hands! Fruit break then do 10 star jumps.	Wash your hands! Fruit Break then do 10 high knees.	Wash your hands! Fruit Break then throw and catch a ball outside.

<p>Middle</p>	<p><b>Mathematics</b> <b>Task 1: TEN</b> <b>Level 1:</b> Roll 2 dot dice. Count all the dots. If the two dice add to 5, place a counter on a ten frame. Keep rolling until you fill the ten frame. <b>Level 2:</b> Roll 2 dot dice. Count all the dots. If the two dice add to 10, place a counter on a ten frame. Keep rolling until you fill the ten frame. <b>Level 3:</b> Roll a numeral die and a dot die. Count on from the numeral die to add the number on the dot die. If the total number adds to 10, place a counter on the ten frame. Keep rolling until you fill the ten frame. <b>Level 4:</b> Roll a dot die and a numeral die. Count backwards to subtract. If the answer is 1 or 0 take one counter away from the ten frame. Keep rolling until you empty the ten frame.</p> <p><b>Task 2: Time</b></p> <ul style="list-style-type: none"> <li>• Watch <a href="#">Telling The Time to O'Clock On Analogue Clocks - YouTube</a></li> </ul> <p><b>Offline Option:</b> Discuss a clock. What do you see? Look at the numbers, hands etc. Discuss o'clock- when the long hand is on the 12 we say o'clock. The short hand tells us the hour or the number before the o'clock.</p>	<p><b>Mathematics</b> <b>Task 1: TEN</b> <b>Level 1:</b> Roll 2 dot dice. Count all the dots. If the two dice add to 5, place a counter on a ten frame. Keep rolling until you fill the ten frame. <b>Level 2:</b> Roll 2 dot dice. Count all the dots. If the two dice add to 10, place a counter on a ten frame. Keep rolling until you fill the ten frame. <b>Level 3:</b> Roll a numeral die and a dot die. Count on from the numeral die to add the number on the dot die. If the total number adds to 10, place a counter on the ten frame. Keep rolling until you fill the ten frame. <b>Level 4:</b> Roll a dot die and a numeral die. Count backwards to subtract. If the answer is 1 or 0 take one counter away from the ten frame. Keep rolling until you empty the ten frame.</p> <p><b>Task 2: Time</b></p> <ul style="list-style-type: none"> <li>• Watch the video: <a href="https://www.youtube.com/watch?v=1eGkW3JnthI">https://www.youtube.com/watch?v=1eGkW3JnthI</a></li> </ul> <p><b>Offline Option:</b> Model how to make the time using a real analogue clock e.g. 1 o'clock etc.</p>	<p><b>Mathematics</b> <b>Task 1: TEN</b> <b>Level 1:</b> Roll 2 dot dice. Count all the dots. If the two dice add to 5, place a counter on a ten frame. Keep rolling until you fill the ten frame. <b>Level 2:</b> Roll 2 dot dice. Count all the dots. If the two dice add to 10, place a counter on a ten frame. Keep rolling until you fill the ten frame. <b>Level 3:</b> Roll a numeral die and a dot die. Count on from the numeral die to add the number on the dot die. If the total number adds to 10, place a counter on the ten frame. Keep rolling until you fill the ten frame. <b>Level 4:</b> Roll a dot die and a numeral die. Count backwards to subtract. If the answer is 1 or 0 take one counter away from the ten frame. Keep rolling until you empty the ten frame.</p> <p><b>Task 2: Time</b> <b>Watch the video:</b> <a href="#">Cluck o'clock by Kes Gray - YouTube</a></p> <p><b>Offline Option:</b> Practice telling the time to the hour using a clock you have at home.</p>	<p><b>Mathematics</b> <b>Task 1: TEN</b> <b>Level 1:</b> Roll 2 dot dice. Count all the dots. If the two dice add to 5, place a counter on a ten frame. Keep rolling until you fill the ten frame. <b>Level 2:</b> Roll 2 dot dice. Count all the dots. If the two dice add to 10, place a counter on a ten frame. Keep rolling until you fill the ten frame. <b>Level 3:</b> Roll a numeral die and a dot die. Count on from the numeral die to add the number on the dot die. If the total number adds to 10, place a counter on the ten frame. Keep rolling until you fill the ten frame. <b>Level 4:</b> Roll a dot die and a numeral die. Count backwards to subtract. If the answer is 1 or 0 take one counter away from the ten frame. Keep rolling until you empty the ten frame.</p> <p><b>Task 2: Time</b> <b>Watch the video:</b> <a href="#">Hip-Hop Around the Clock   Learn How to Tell Time   Jack Hartmann - YouTube</a></p> <p><b>Offline Option:</b> Have a look at a clock and point to each number and say the o'clock.</p>	<p><b>Mathematics</b> <b>Task 1: TEN</b> <b>Level 1:</b> Roll 2 dot dice. Count all the dots. If the two dice add to 5, place a counter on a ten frame. Keep rolling until you fill the ten frame. <b>Level 2:</b> Roll 2 dot dice. Count all the dots. If the two dice add to 10, place a counter on a ten frame. Keep rolling until you fill the ten frame. <b>Level 3:</b> Roll a numeral die and a dot die. Count on from the numeral die to add the number on the dot die. If the total number adds to 10, place a counter on the ten frame. Keep rolling until you fill the ten frame. <b>Level 4:</b> Roll a dot die and a numeral die. Count backwards to subtract. If the answer is 1 or 0 take one counter away from the ten frame. Keep rolling until you empty the ten frame.</p> <p><b>Task 2: Time</b> <b>Watch the video:</b> <a href="#">Hip-Hop Around the Clock   Learn How to Tell Time   Jack Hartmann - YouTube</a></p> <p>Complete the worksheets</p>
---------------	---	--	--	---	---

- Using the PowerPoint to look at o'clock and tell the time to the hours by looking at the hands.
- Complete the clock face template to make a clock. What time can you make with the hands?

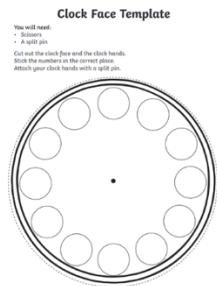

**Task 3: Mathseeds**  
Log on and participate in Mathseeds levels.

**Optional Independent Activity: Maths Worksheet**

- Remind them how the long hand on the 12 makes o'clock and the short hand is the number (hour).
- Use the clock you made yesterday and give your child multiple times e.g. 5 o'clock, see if they can show you with the correct hands in the right place. Continue to test and teach the right hands.
- Extension: you can add in half past, only if you feel they have o'clock down pat.

**Task 3: Mathseeds**  
Log on and participate in Mathseeds levels.

**Optional Independent Activity: Maths Worksheet**

Complete the What's the time Mr Wolf Board Game with an adult.

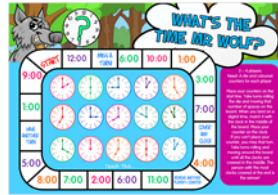

**Task 3: Mathseeds**  
Log on and participate in Mathseeds levels.

**Optional Independent Activity: Maths Worksheet**

Complete the worksheet and match the analogue and digital clocks.

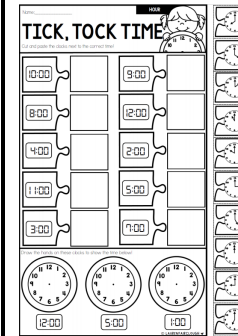

**Task 3: Mathseeds**  
Log on and participate in Mathseeds levels.

**Optional Independent Activity: Maths Worksheet**



**Task 3: Mathseeds**  
Log on and participate in Mathseeds levels.

**Optional Independent Activity: Maths Worksheet**

Break

Wash your hands!  
Lunch – Help make your own sandwich.

Wash your hands!  
Lunch – Eat outside in the sunshine.

Wash your hands!  
Lunch - Have a picnic inside.

Wash your hands!  
Lunch – Draw on the concrete outside with chalk!

Wash your hands!  
Lunch – Draw a picture of what you had for lunch.

Afternoon

### Happier Schools

Read 'Looking after yourself' in the PowerPoint/CoL-WaH booklet and answer the questions on the last page by either writing or by talking about them with an adult.



### Visual Arts

Watch the Art for Kids Hub video 'How to draw a funny loaf of bread' or try to draw a funny loaf of bread by yourself <https://www.youtube.com/watch?v=SsE3anpHSZg>



### Science

Watch YouTube Video of How Does Corn Grow? By Haley Gillman. Begin video at 1.02 minutes and stop it at 5.10 minutes. <https://www.youtube.com/watch?v=Yp5o25PjBcw>. NB It has some American language in the clip so you will need to explain terms such as 'fall' or 'gas' etc.

#### Online and Offline Option:

- Discuss with an adult:
- What does corn look like?
- Where and how does it grow? Climate, height
- What products are made from corn? Cereal, chips, popcorn, flour

Watch video of Wheat on YouTube : Farm to Market: Wheat(Clips) [https://www.youtube.com/watch?v=ae\\_OBMFkaEA](https://www.youtube.com/watch?v=ae_OBMFkaEA)

#### Online and Offline Option:

- Discuss with an adult
- What is wheat?
  - Where do we find wheat/what are the best times to grow it?
  - What does it look like?
  - What is it used for? Bread, cereal, flour, tortillas, pasta, muesli bars pizza, doughnuts, cakes.

**Option Independent Activity:**  
**Corn and Wheat Colouring in page.**

### Physical Education

Follow along with the Get Active video and learn bouncing skills and drills

[GetActive@Home Kindergarten-Year 2 Episode 5 on Vimeo](#)

Or go outside and practice bouncing by yourself or with a partner



**Offline Option:** go outside and practice bouncing a ball by yourself or with someone from your family.

### Geography

We are learning about people in our community.

Watch the YouTube Video: Communities for Kids - Types of Communities | Social Studies for Kids | Kids Academy <https://youtu.be/IGC0zxrRNJQ>

- Choose a group that you belong to. Think of a time that you celebrated together e.g. Christmas, a performance, a grand final match or a fete.
- Draw a picture of your group celebrating this event.
- Describe how you felt participating in this celebration.

Group Celebrations

Draw a picture of your group celebrating the event.

Describe how you felt participating in this celebration.

---

---

---

**Offline Option: Discuss with an adult:** Brainstorm different communities you belong to. Choose one of your groups and discuss a time you celebrated with that group. Draw a picture of the celebration.



**Monday**

**This page has been intentionally left blank.**





The loaves are then sliced, packaged and delivered to the shop to be sold.

twinkl [twinkl.com](https://www.twinkl.com)



The sacks of flour are driven to a bakery.

twinkl [twinkl.com](https://www.twinkl.com)

Where does bread come from?

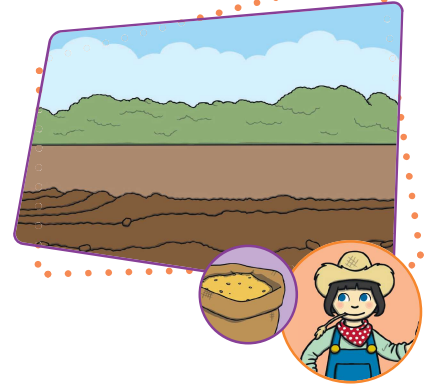

Seeds are sown in a field.

twinkl [twinkl.com](https://www.twinkl.com)



The baker mixes flour together with other ingredients such as yeast, sugar, water and salt.

twinkl [twinkl.com](https://www.twinkl.com)



The seeds grow into wheat which is then harvested.

twinkl [twinkl.com](https://www.twinkl.com)



This is put into an oven and baked.

twinkl [twinkl.com](https://www.twinkl.com)

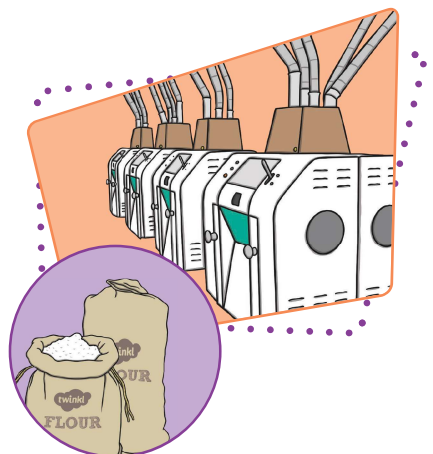

The wheat is ground down to make flour.

twinkl [twinkl.com](https://www.twinkl.com)

**This page has been intentionally left blank.**

# OPTIONAL TASK

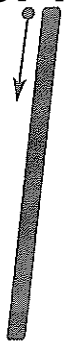

Trace.

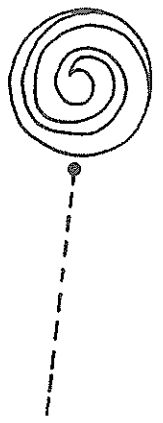
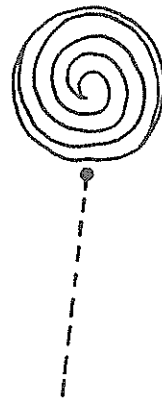
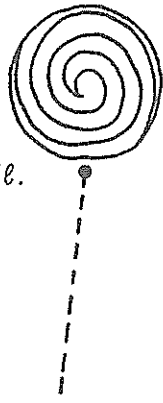

Find I.

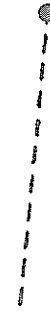
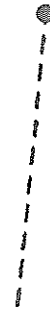
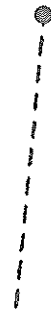
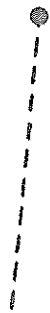
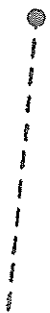
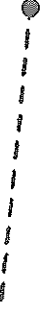
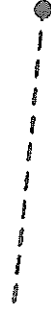
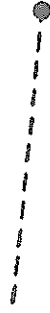
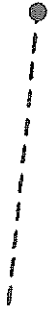

Try your own.



# OPTIONAL TASK

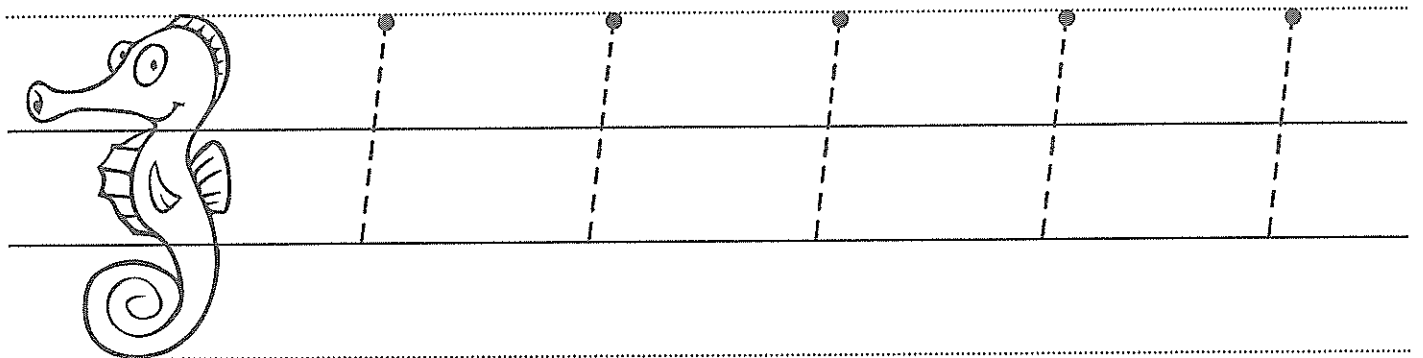
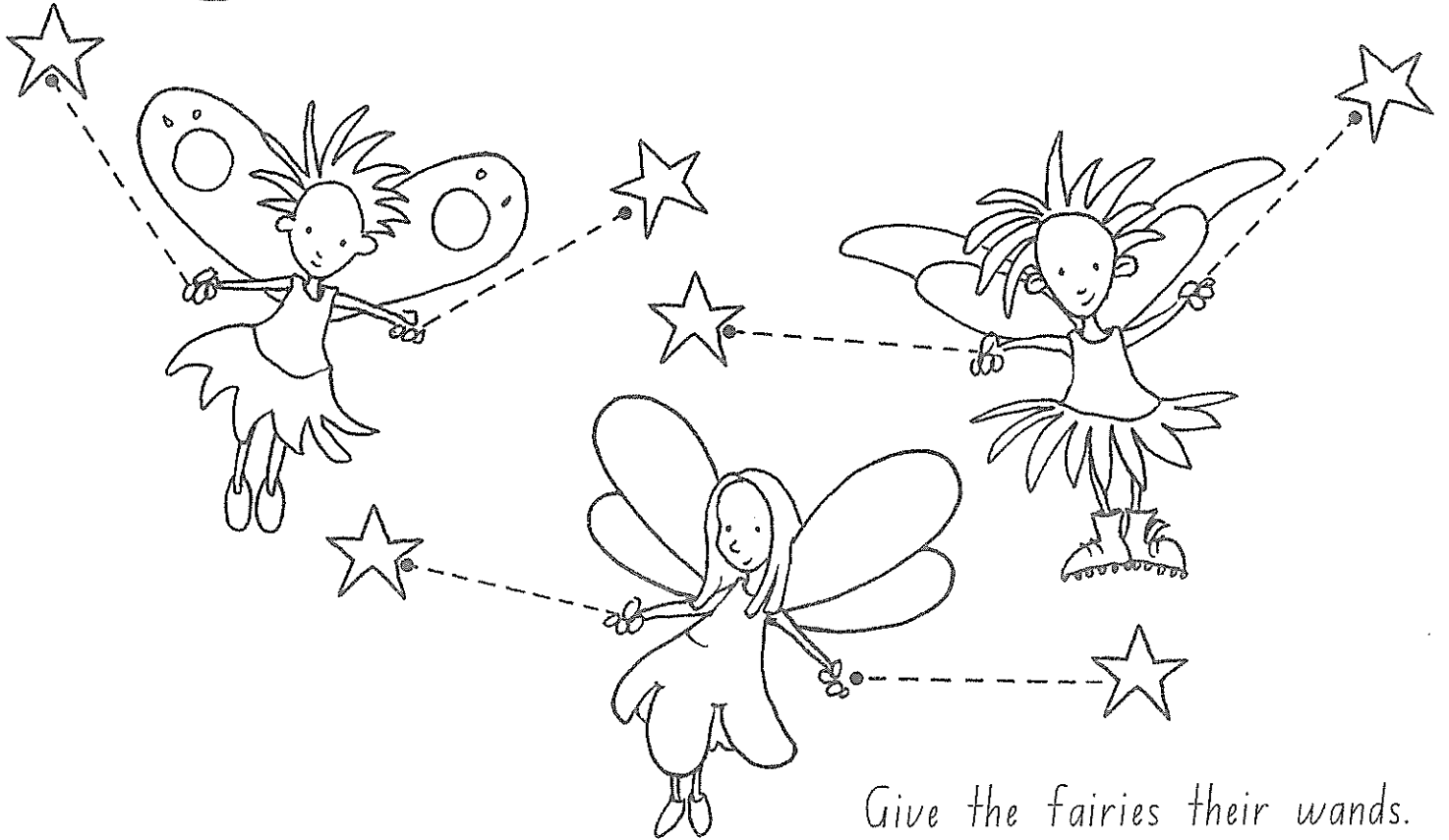
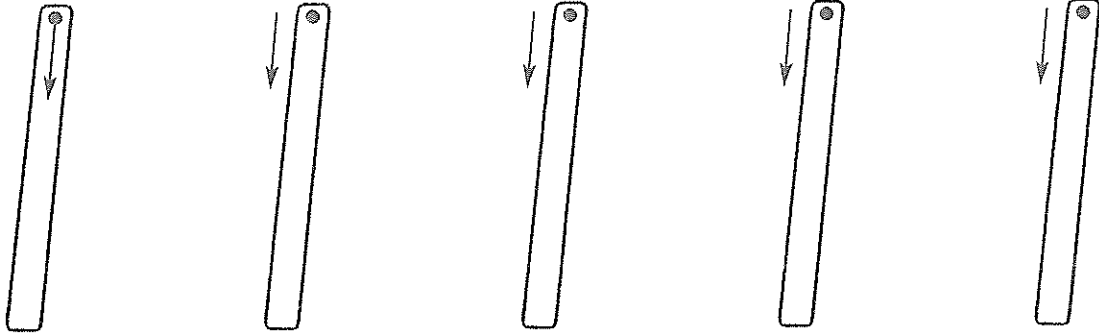
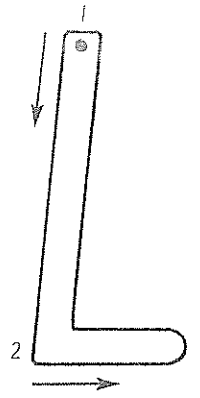
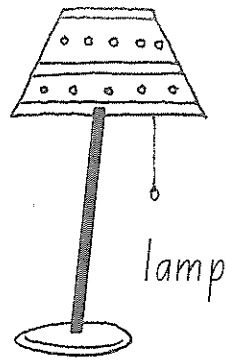
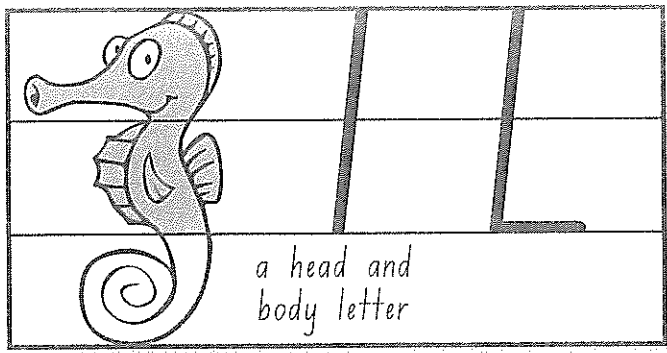

# OPTIONAL TASK

Name: \_\_\_\_\_

# Spell & Find

Spell and find the words.



n	e	t	b	p	l
r	f	m	e	j	e
d	s	p	d	l	g
n	g	e	h	c	k
t	e	n	j	e	t

ten
leg
net
pen
bed
jet

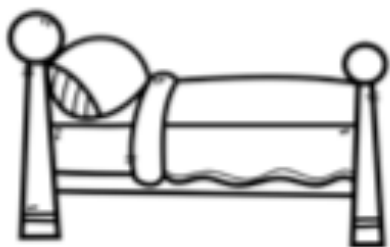

--	--	--



--	--	--



--	--	--

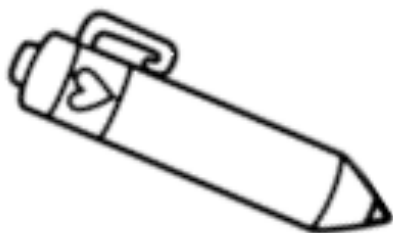

--	--	--



--	--	--

10

--	--	--

**This page has been intentionally left blank.**

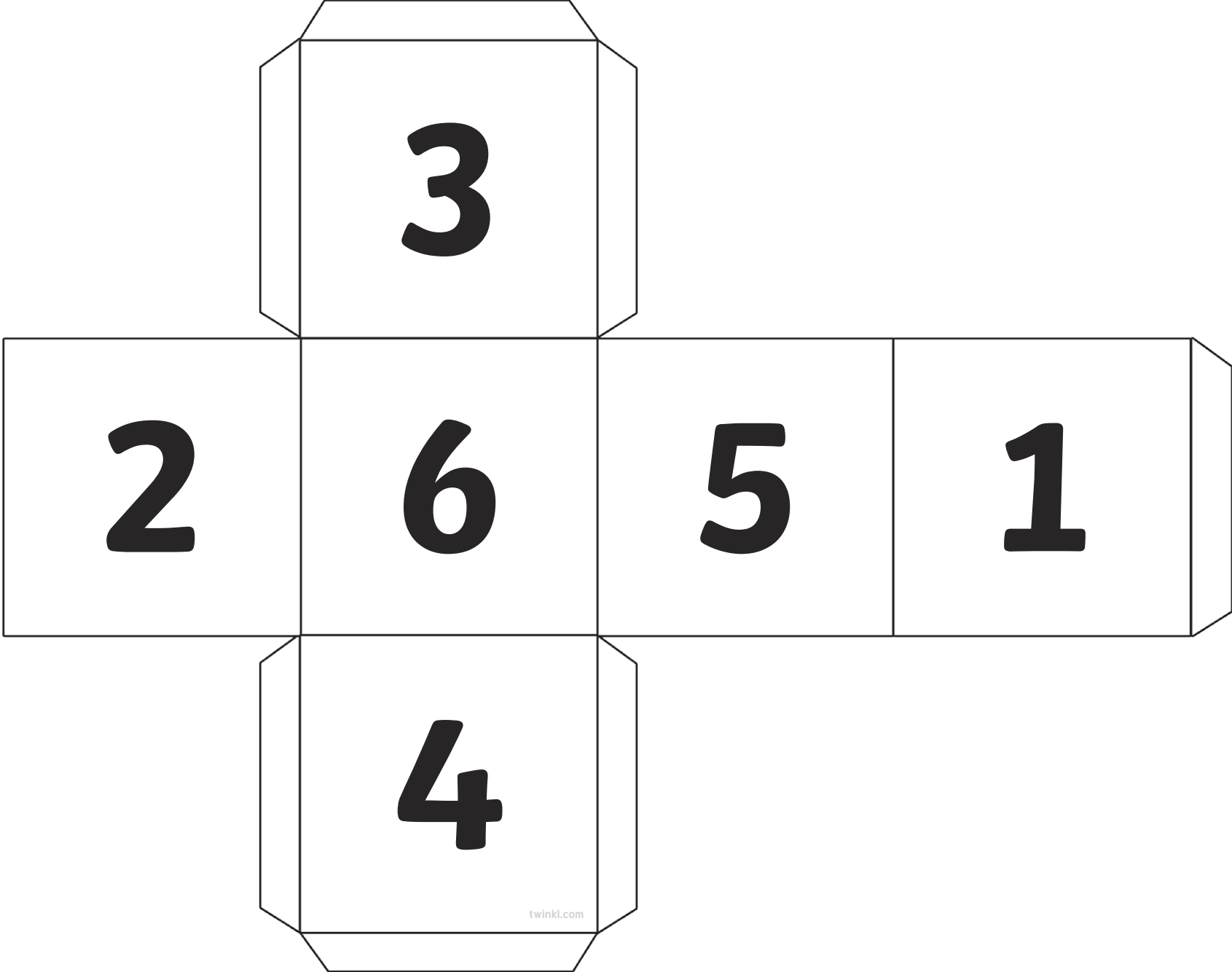

**This page has been intentionally left blank.**



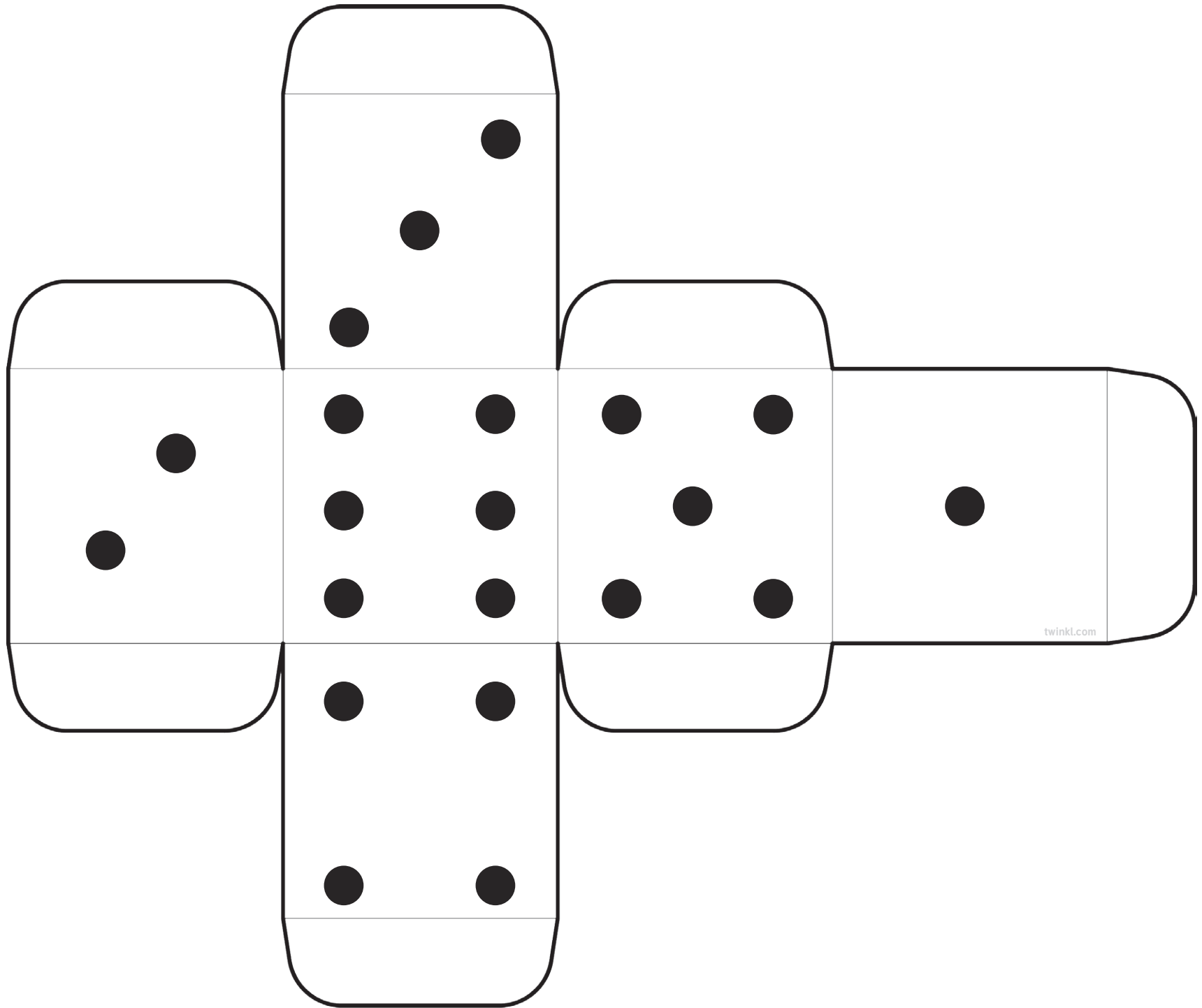

**This page has been intentionally left blank.**

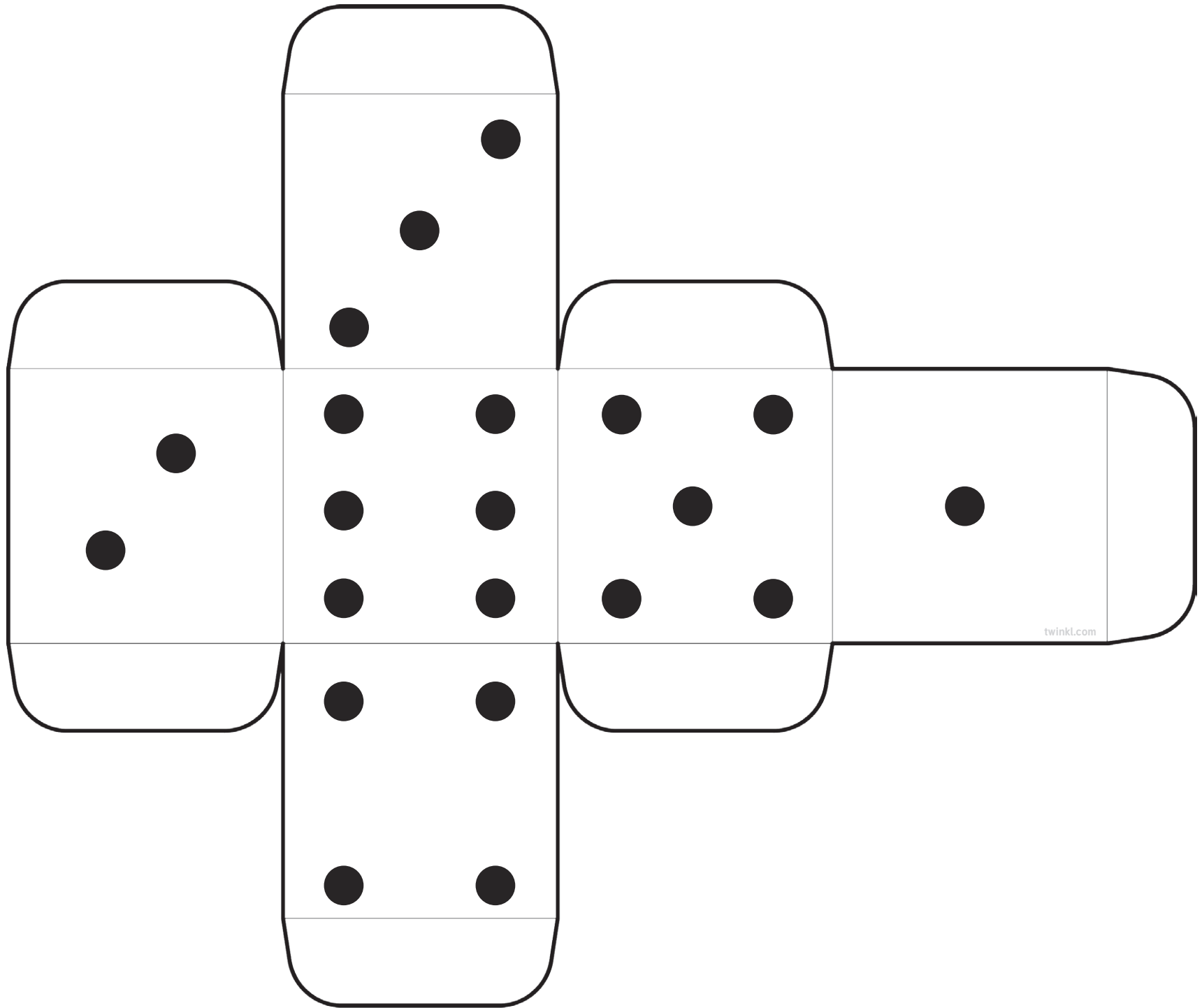

**This page has been intentionally left blank.**



**This page has been intentionally left blank.**

# Clock Face Template

You will need:

- Scissors
- A split pin

Cut out the clock face and the clock hands.

Stick the numbers in the correct place.

Attach your clock hands with a split pin.

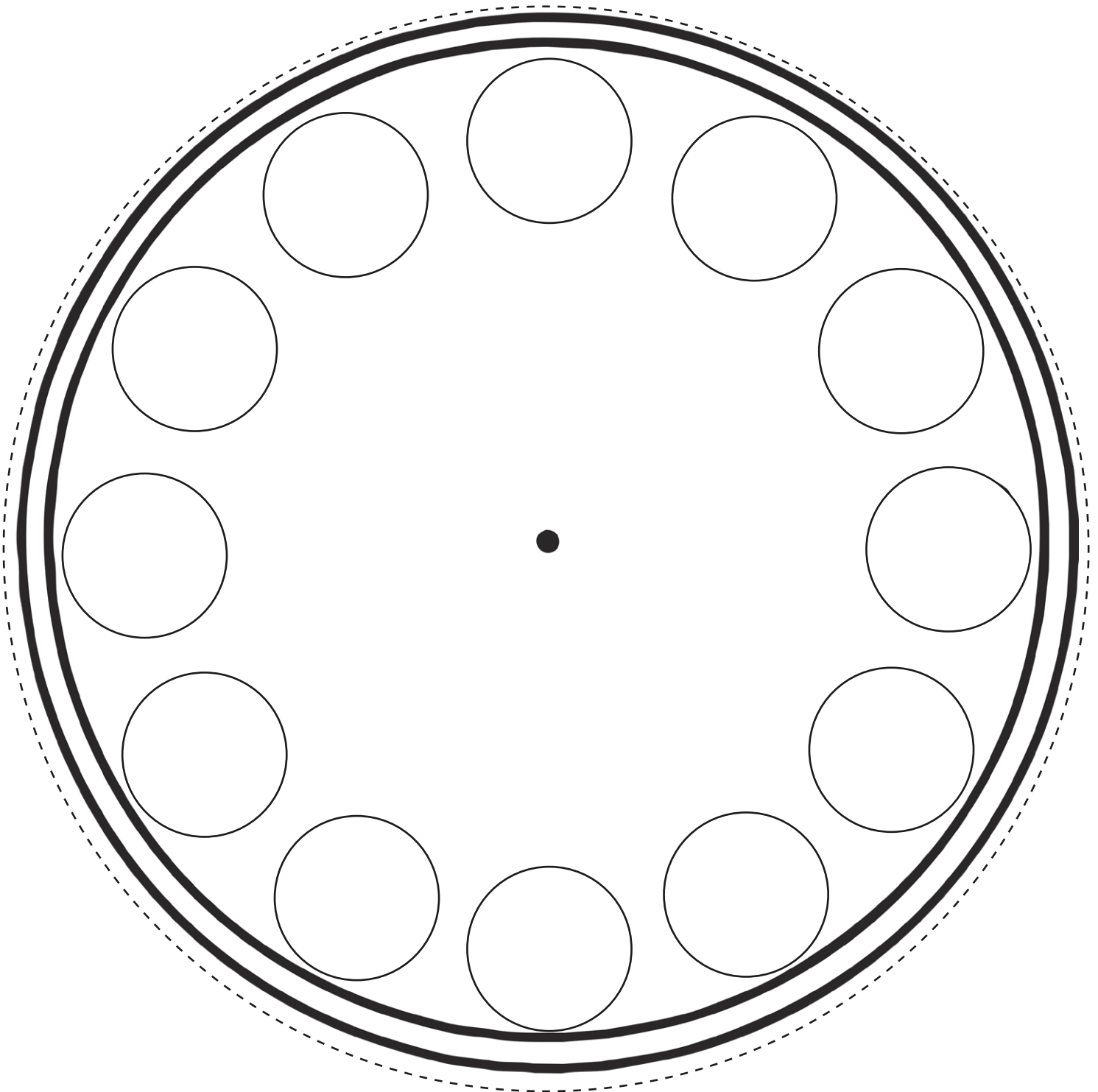

**This page has been intentionally left blank.**



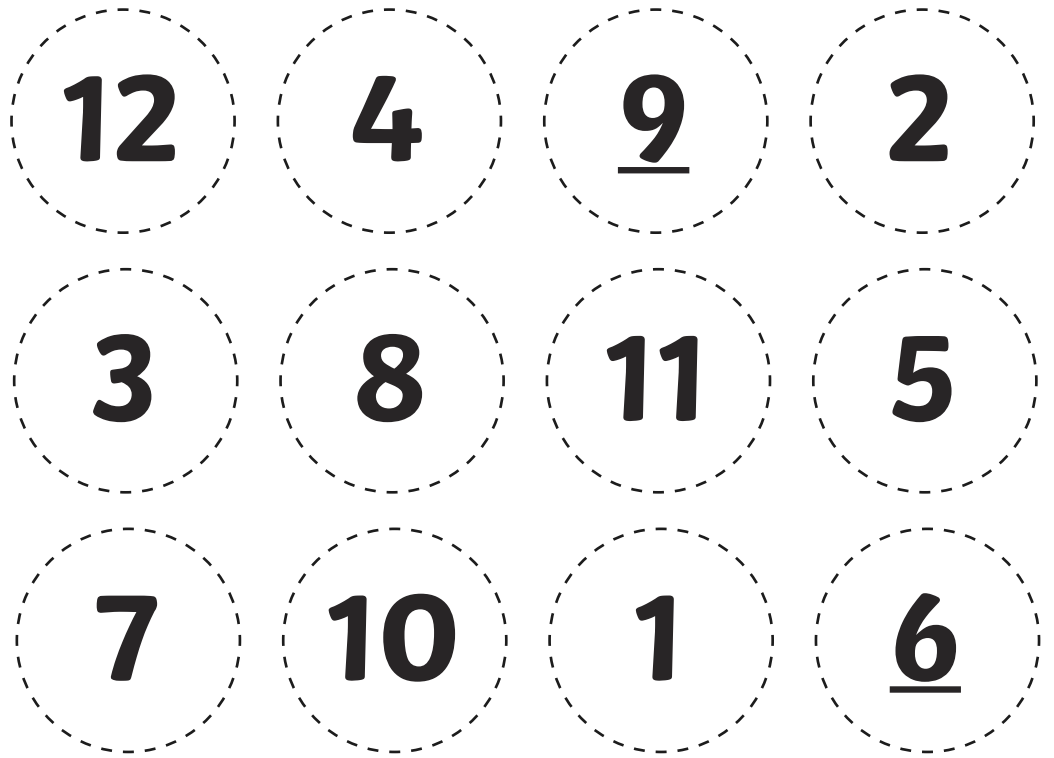
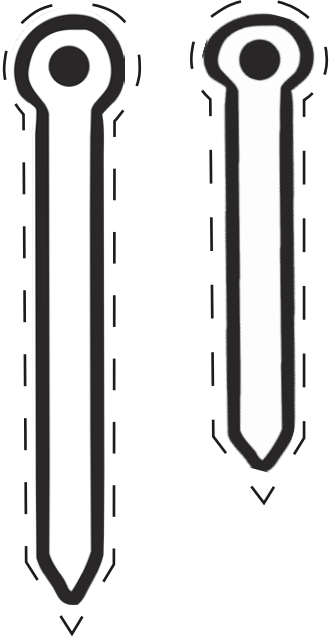

**This page has been intentionally left blank.**

# OPTIONAL TASK

Addition to 10

Name: \_\_\_\_\_

# Color by Number: Winter

Use the code below to color the picture!

1 one	purple	2 two	orange	3 three	light blue	4 four	green
5 five	pink	6 six	red	7 seven	dark blue	8 eight	yellow

© 2020 The Primary Partner | Libby Kliner Teaching LLC

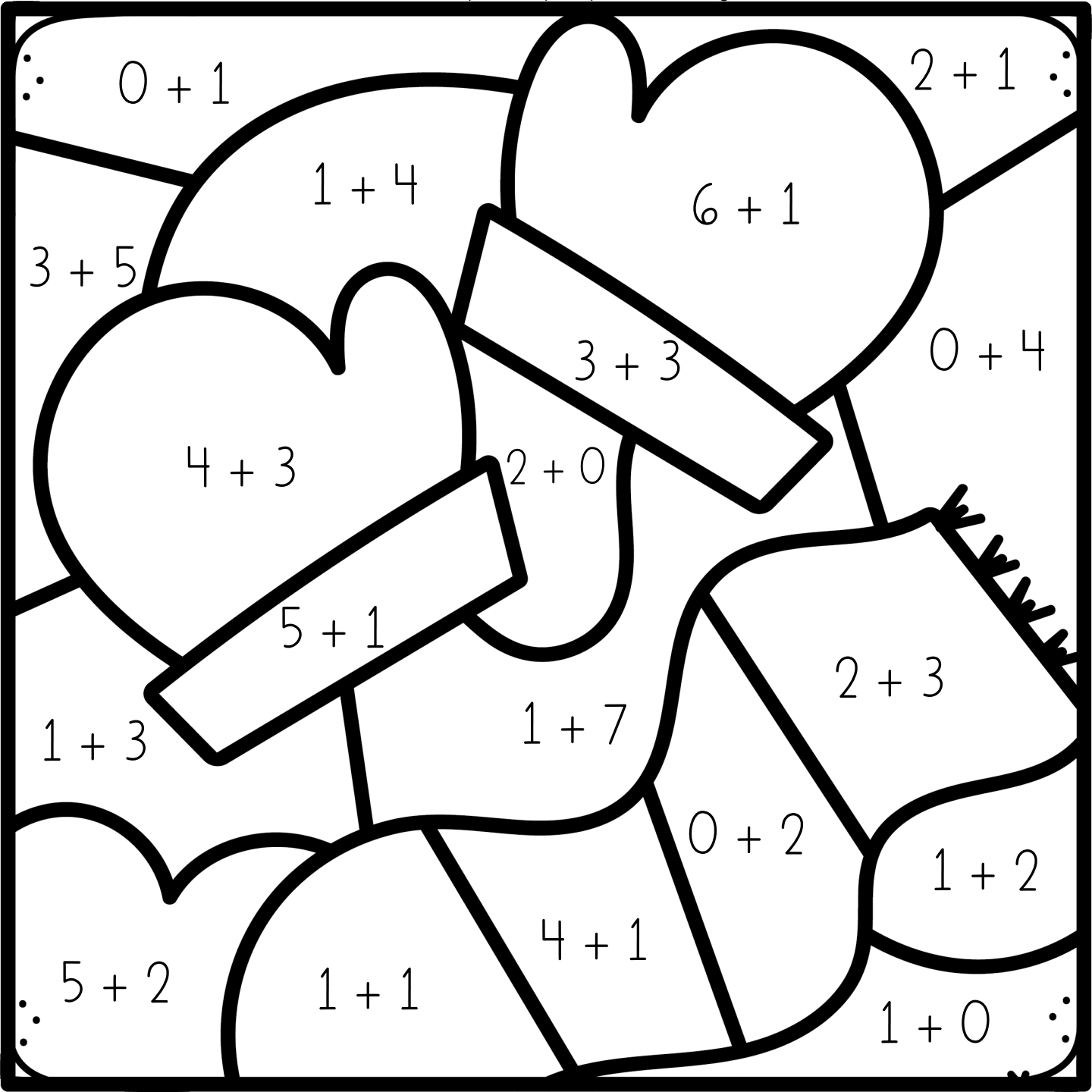



**Dangerous**  
**Dragsters**

Author: Ivan Honey  
Illustrator: Jacqui Lynch

Dragsters are so fast that sometimes you may not even see them zipping by.

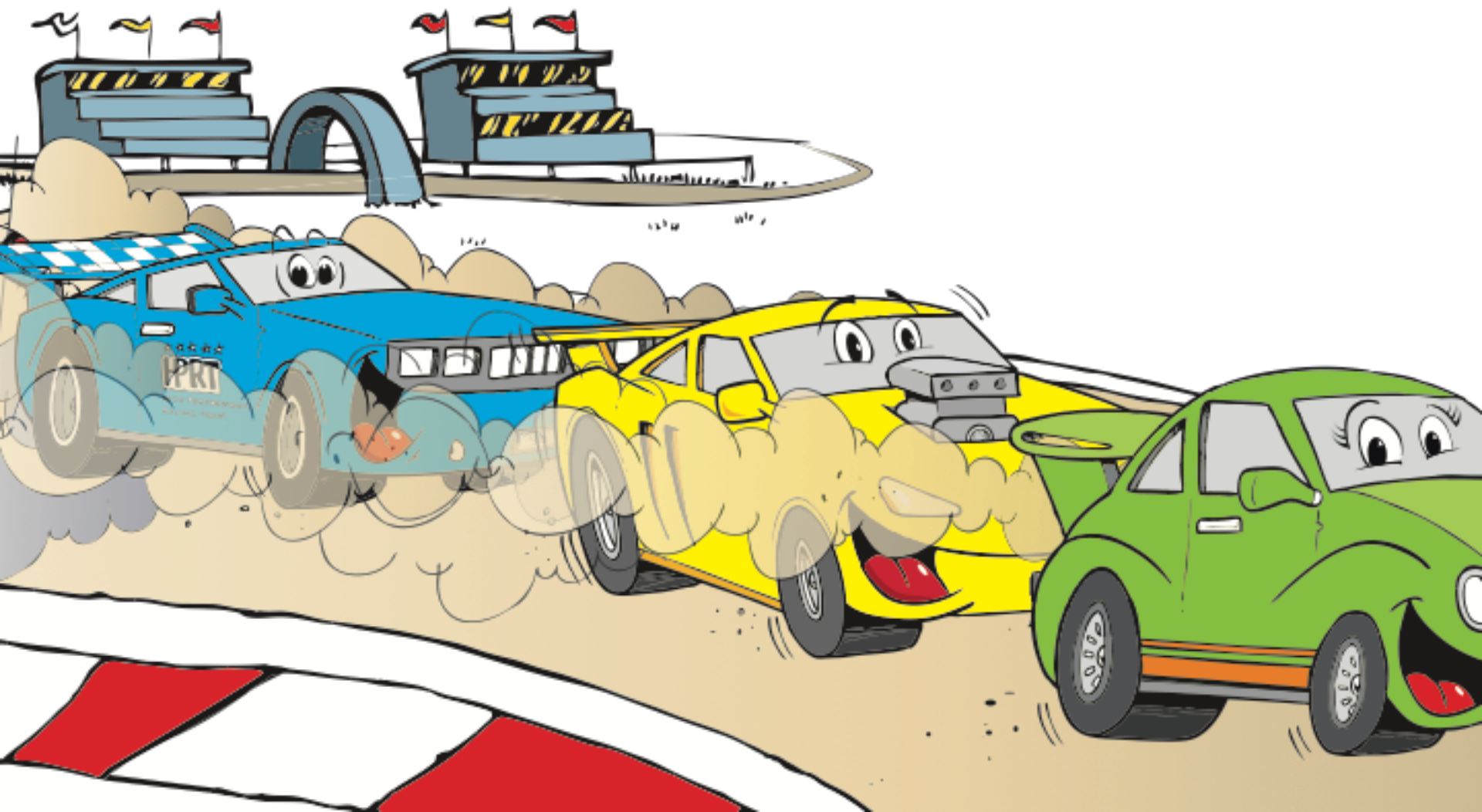

That is why Sid Sideswiper looks carefully to make sure he doesn't crash.

It's no fun when he gets hurt or hurts others.

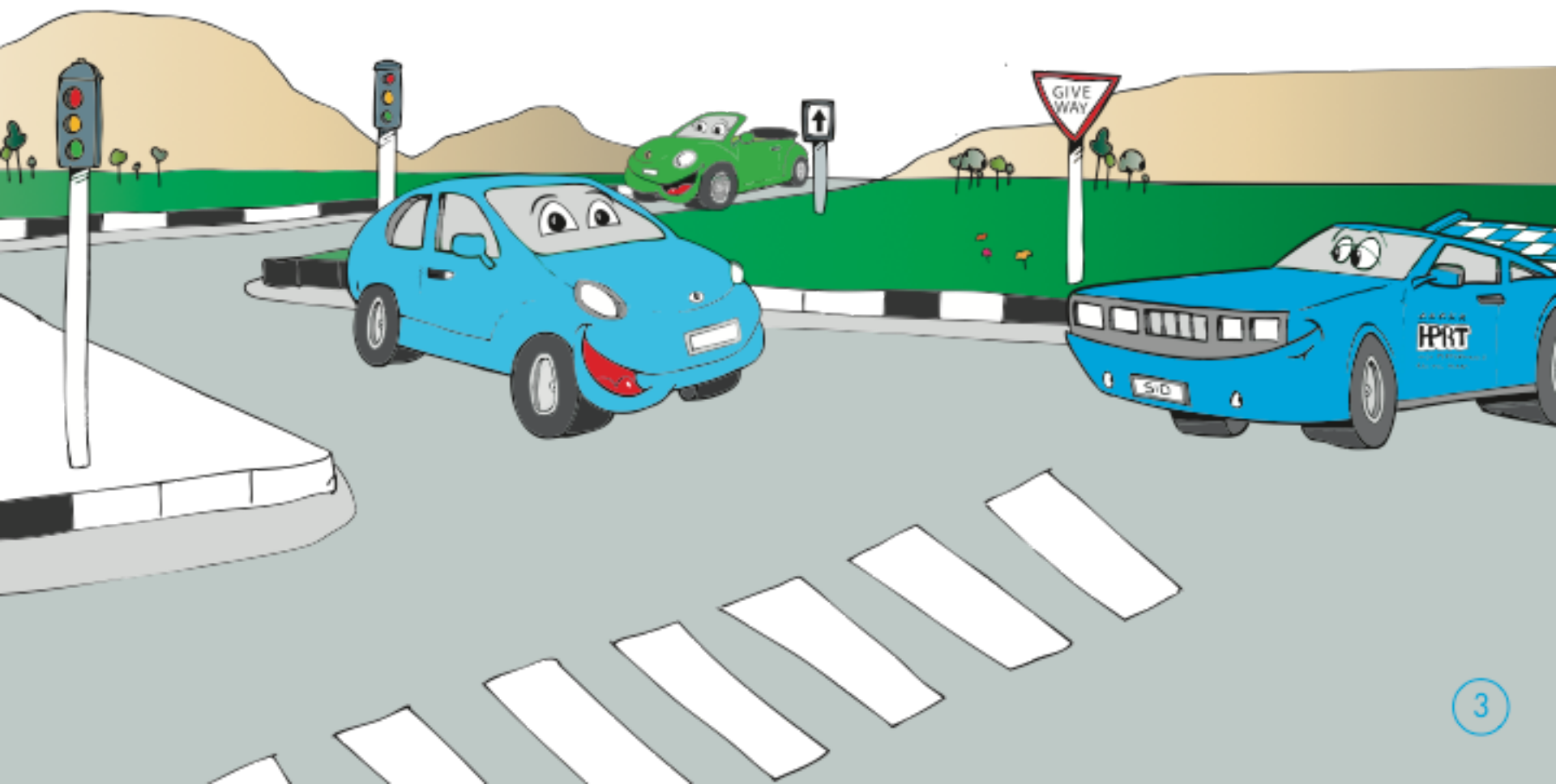

Sid says, 'Be smart when you drive your car.

Keep yourself safe. It's easy to forget how powerful you are!'

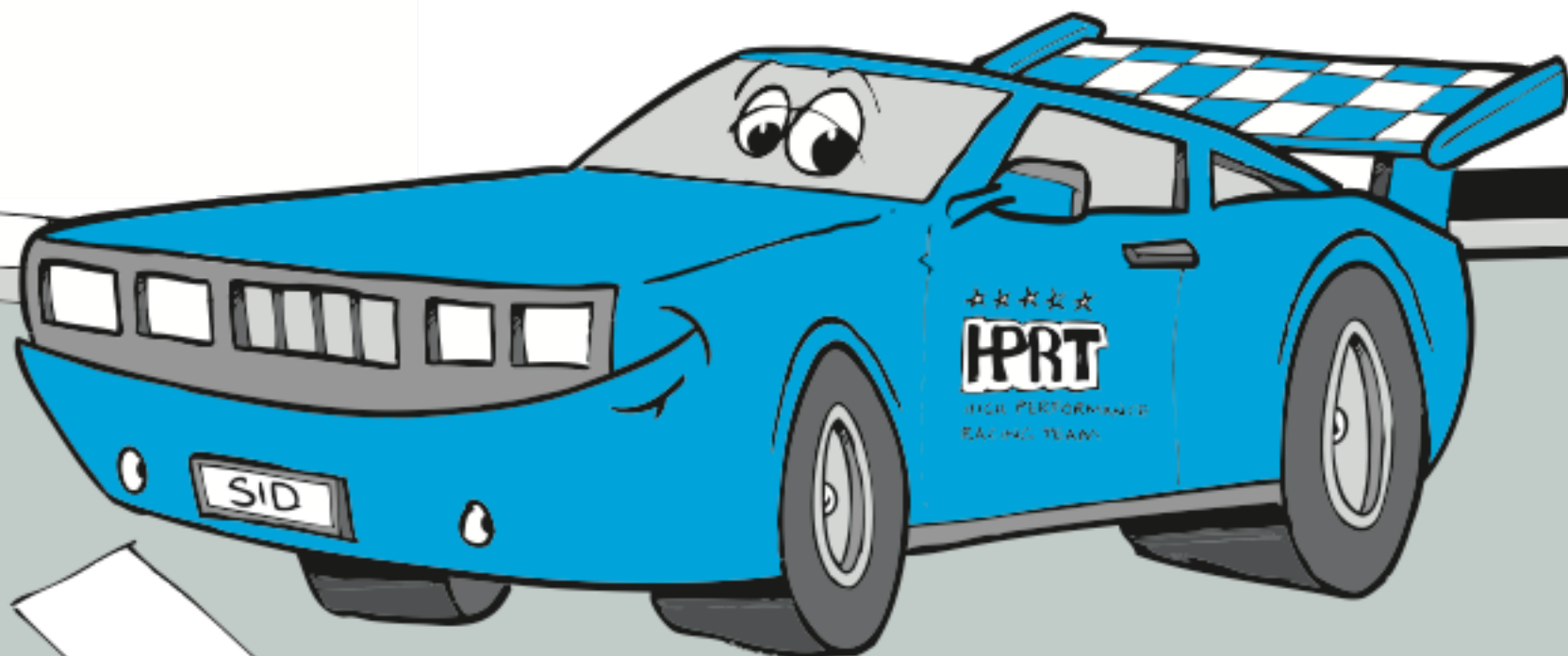



There are lots of dragsters zooming around everywhere, so stick to the road rules and drive carefully.

*In the school yard, always drive carefully!*

*Wait for the green light!*



*If there are no traffic lights,  
Look Right!  
Look Left!  
Look Right again  
and then cross the road.*





The dragsters only race on the drag track.

If they are with ordinary cars on the road, dragsters are careful and kind.

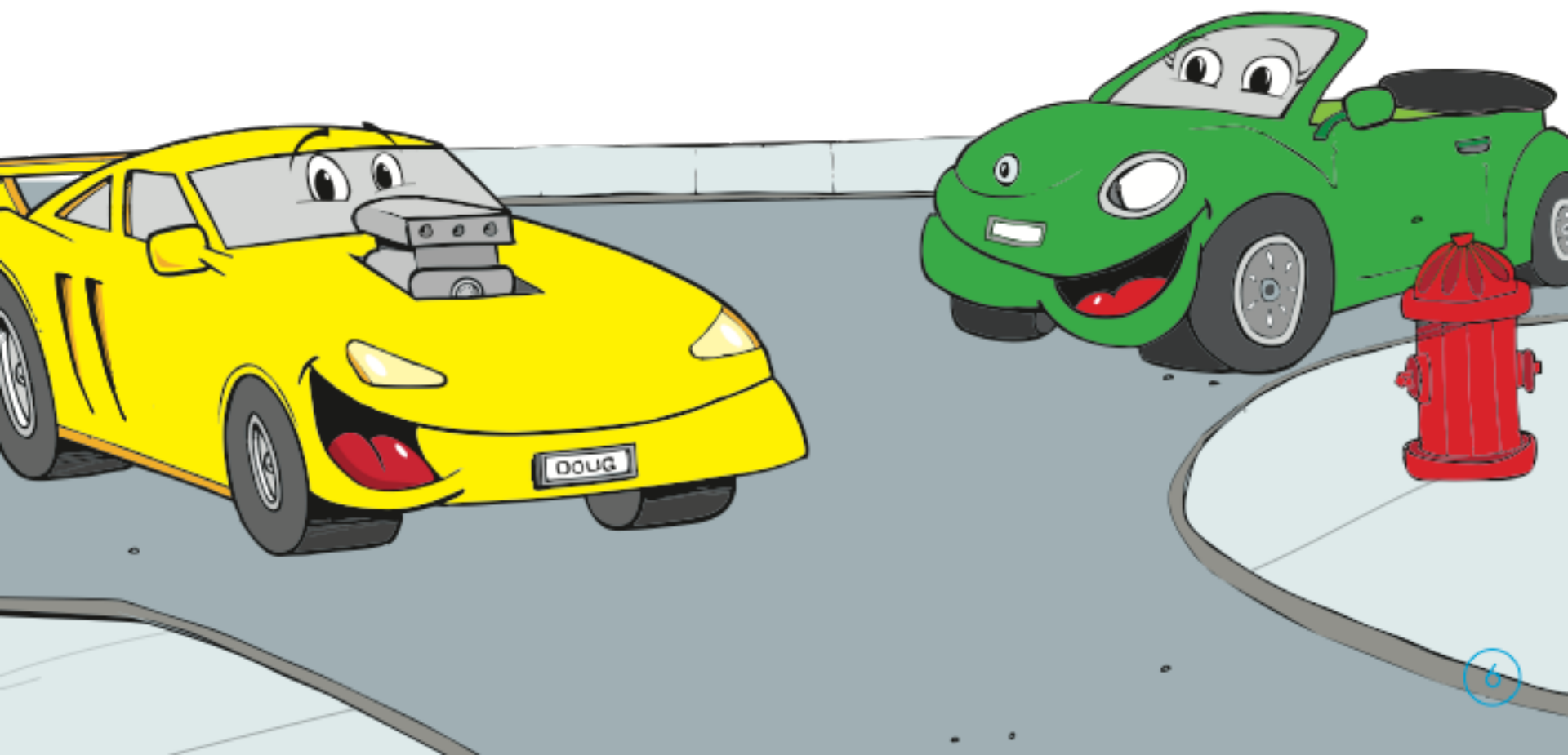

**Sid Says:**

**SO STAY  
SAFE  
LIKE THE  
DRAGSTERS  
DO!**



## Sid Says:

Make a list of the rules to keep yourself and others safe!

How do we keep safe:

- in the playground?
- in our classroom?
- at home?
- in our community?





DOUG DRAGSTER™

Published in 2017 by Ivan Honey and Associates Pty Ltd  
Ivan Honey and Associates Pty Ltd  
PO BOX 126 Strathfieldsaye  
Victoria 3551 Australia  
Ph: 03 5439 5551

Website: [www.gethappier.net](http://www.gethappier.net)  
Email: [admin@ivanhoney.com](mailto:admin@ivanhoney.com)

©Ivan Honey and Associates Pty Ltd 2017

This publication is copyright. Other than for the purposes of and subject to conditions prescribed under the Copyright Act, no part of it may in any form or by any means (electronic, mechanical, micro copying, photocopying, recording or otherwise) be reproduced, stored in retrieval system or transmitted without prior written permission.

Author: Ivan Honey  
Design by Jacqui Lynch, Preloaded Design  
Illustrations by Jacqui Lynch, Preloaded Design and Mat Jones



Tuesday

# Grains

Grain is the seeds of some special kinds of grass. The main types of commercial grain crops are cereals. People grow different kinds of grain as food. The different kinds of grain are perhaps one of the most important foods in the world.

Some kinds of grain are:

Barley

Maize or American corn

Millet

Oats

Rice

Wheat



87% of all grain grown by farmers around the world is maize. Grains contain carbohydrates that people can eat. In poorer countries, grains are a large part of the food supply. In richer countries, they are still important as food, but not as important as in poorer countries. Growing grain uses a lot of water. About 1,000 tons of water is needed to grow one ton of grain.

Many different foods are made from different types of grain. Grain is often ground into a powder called flour. Flour can be made into breads, cakes, or noodles.

Different kinds of beer are made from barley malt, wheat, and other grains.

Tortillas are made from a special flour of maize (corn) called masa.

# Wheat

Wheat is a cereal grain. People eat it most often in the form of bread. It is a kind of grass whose fruit is a "head of wheat" with edible seeds. It was first grown in the Levant, a region of the Near East. Now it is cultivated worldwide.

The wheat plant has long, slender leaves, stems that are hollow in most types of wheat plants, and heads that have many kinds of flowers, from 20 to 100. The flowers are grouped together in spikelets. Each spikelet has two to six flowers. In most spikelets, two or three of the flowers become fertilized, and this makes them produce the grains used for food.

Wheat grain is a staple food used to make flour for leavened, flat and steamed breads, biscuits, cookies, cakes, breakfast cereal, pasta, noodles, couscous. It can also be fermented to make ethanol, for alcoholic drinks, or biofuel.

An allergy to wheat can cause coeliac disease, which makes the sufferer have diarrhoea if they eat any food containing wheat.





A large rectangular frame with a thick black border, containing a series of horizontal dashed lines for writing. The lines are evenly spaced and extend across most of the width of the page. There are small dots in the top-left and bottom-right corners of the inner writing area.

# OPTIONAL TASK

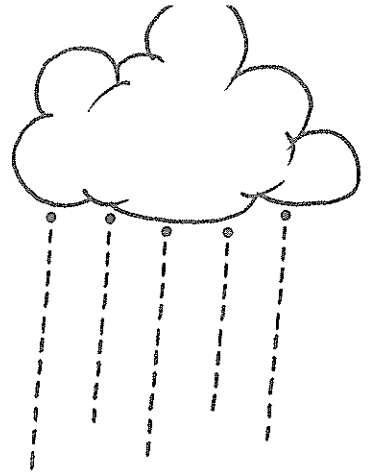
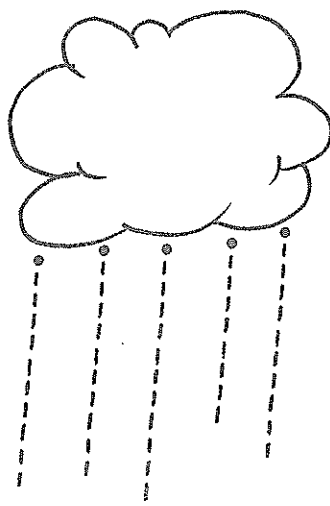
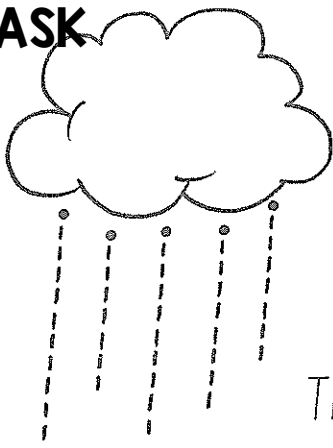
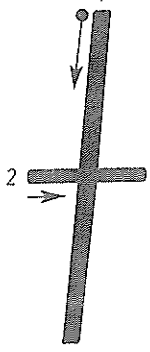

Trace.

Trace. Find t.

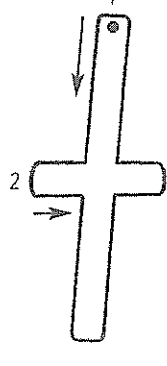
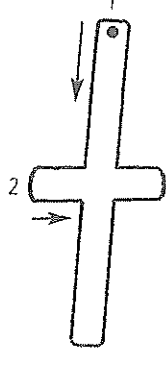
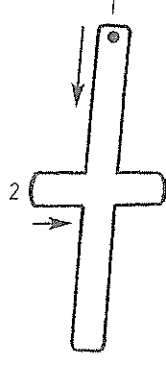
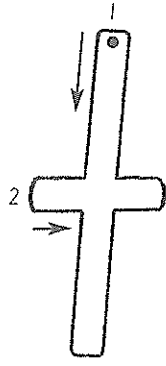
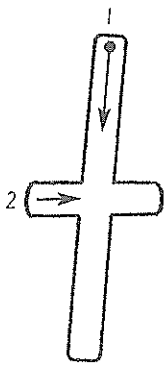
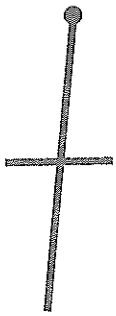

Try your own.





# OPTIONAL TASK

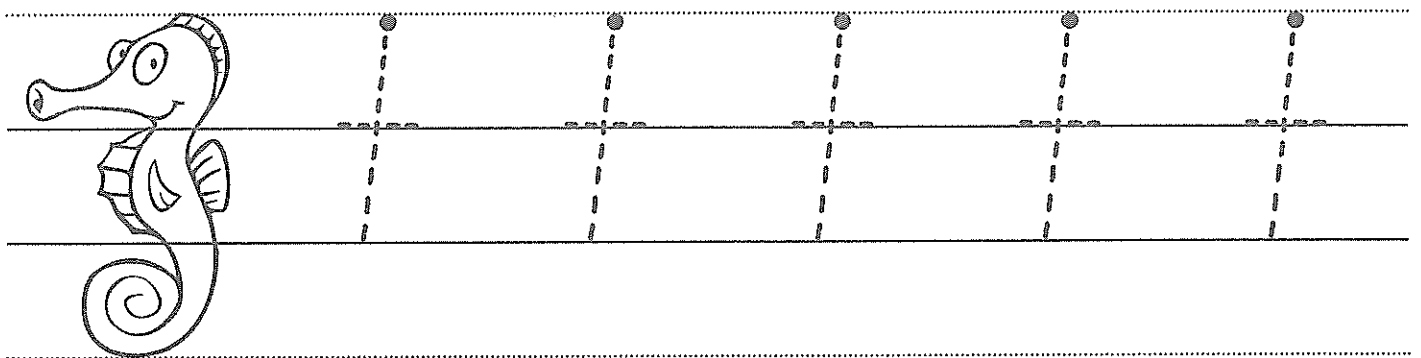
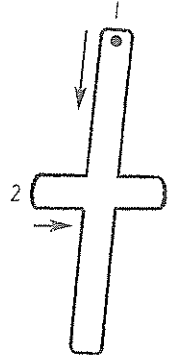
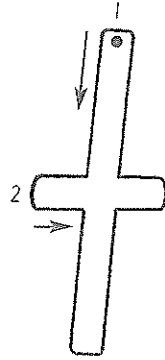
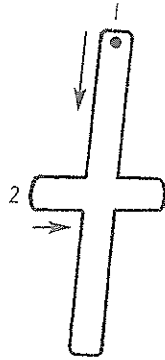
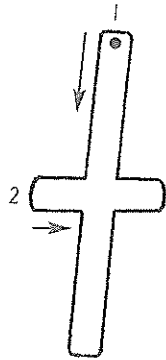
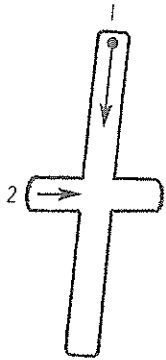
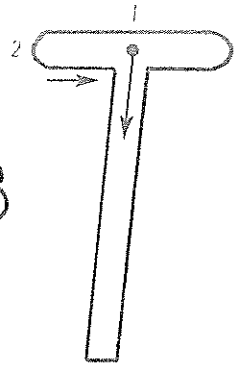
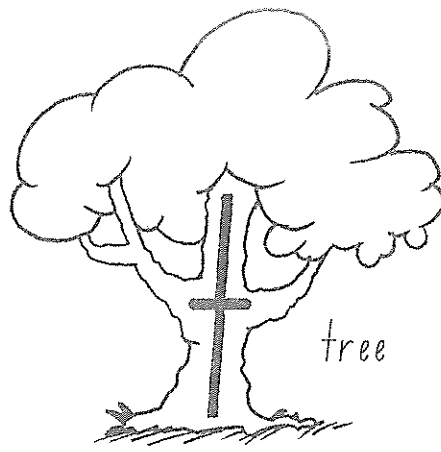
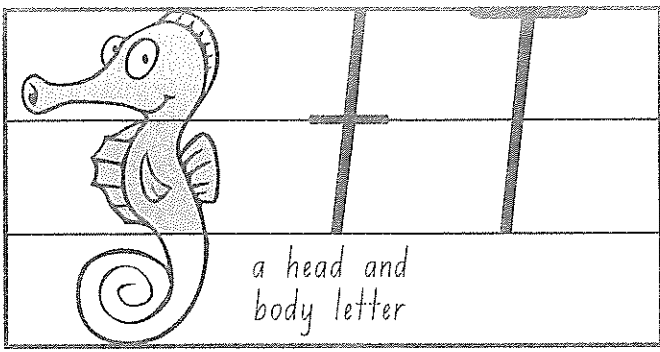

# OPTIONAL TASK

Name: \_\_\_\_\_

# Word search



- |                           |                           |                           |
|---------------------------|---------------------------|---------------------------|
| <input type="radio"/> bug | <input type="radio"/> pot | <input type="radio"/> ten |
| <input type="radio"/> can | <input type="radio"/> map | <input type="radio"/> sun |
| <input type="radio"/> pig | <input type="radio"/> hat | <input type="radio"/> leg |
| <input type="radio"/> cop | <input type="radio"/> cup | <input type="radio"/> bin |



# OPTIONAL TASK

Addition to 10

Name: \_\_\_\_\_

# Color by Number: Winter

Use the code below to color the picture!

1 one	yellow	2 two	orange	3 three	blue	4 four	green
5 five	red	6 six	pink	7 seven	brown	8 eight	purple

© 2020 The Primary Partner | Libby Klinner Teaching LLC

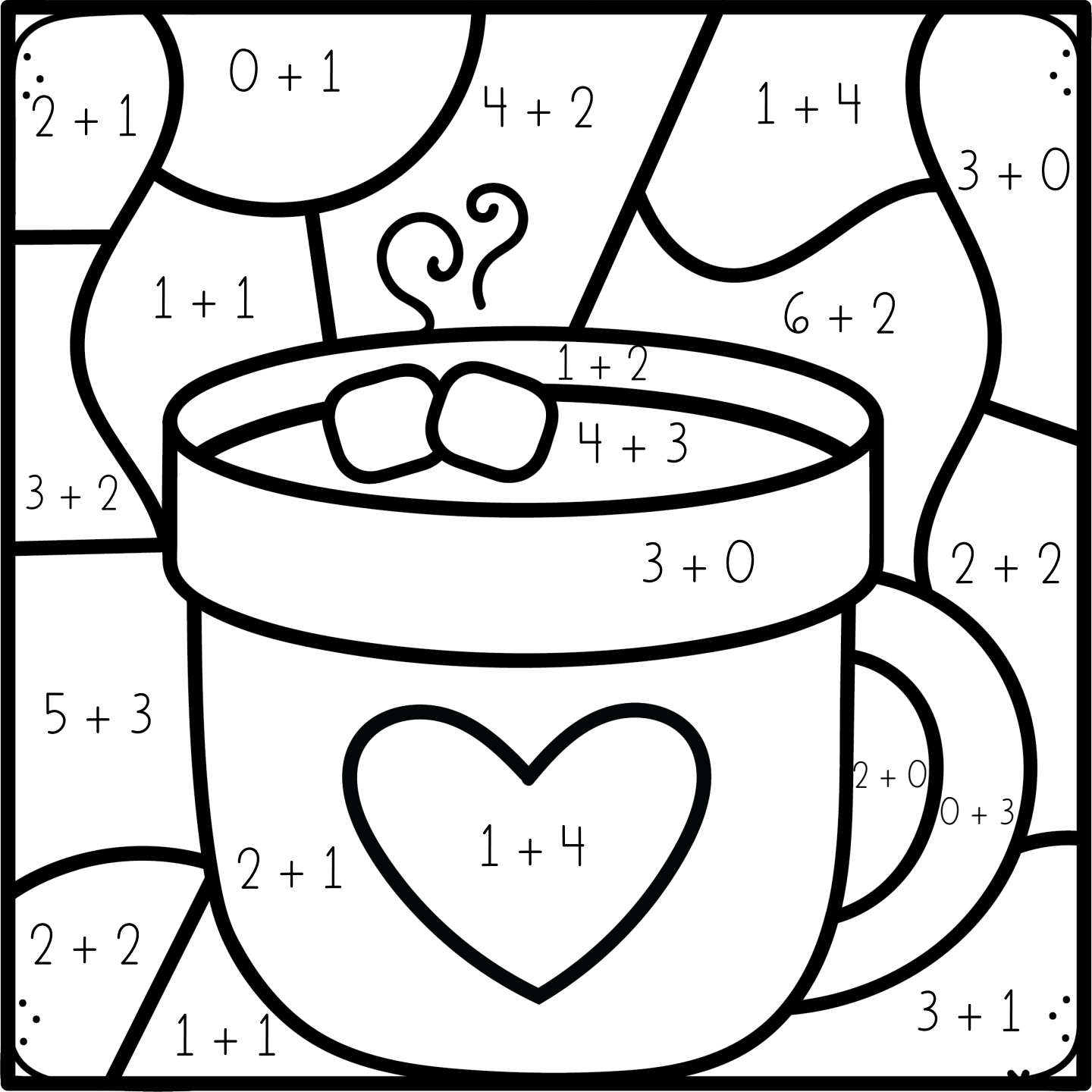



Wednesday



# OPTIONAL TASK

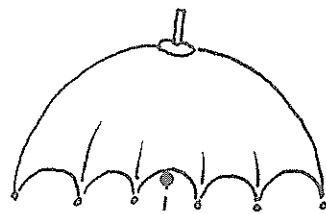

Trace.

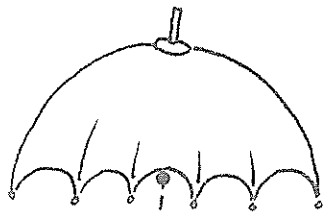
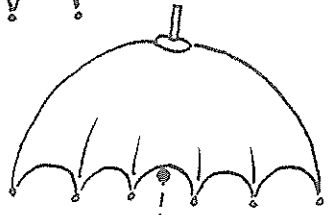
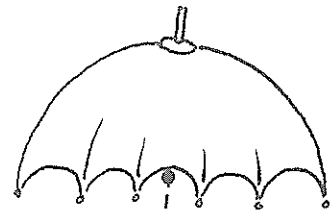
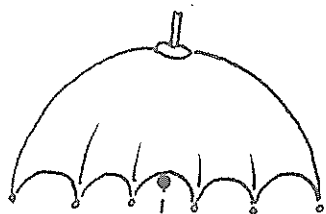

Trace. Find i.

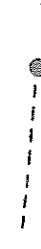
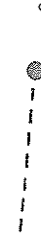
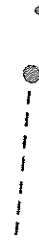
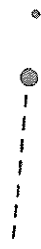
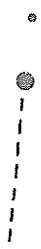
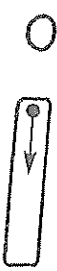
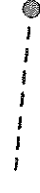
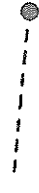
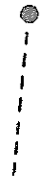
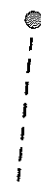
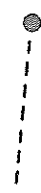

Try your own.



# OPTIONAL TASK

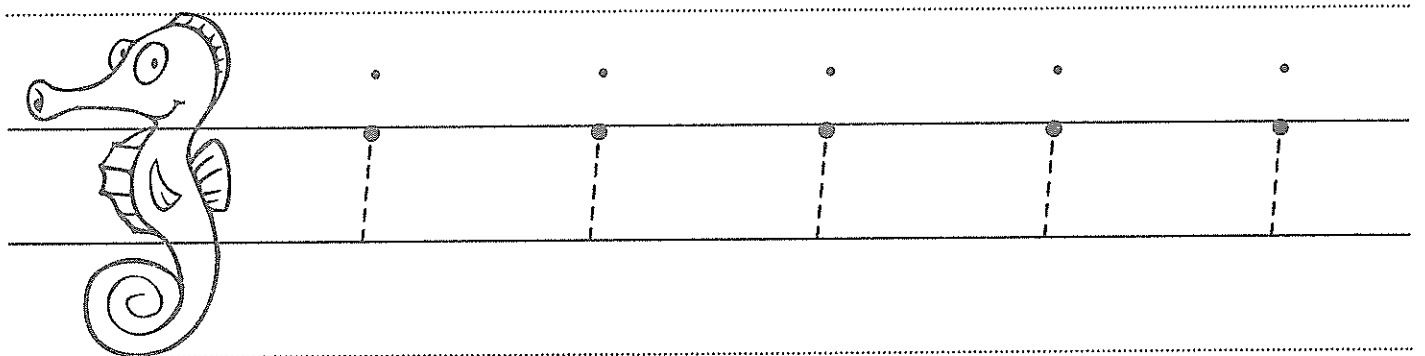
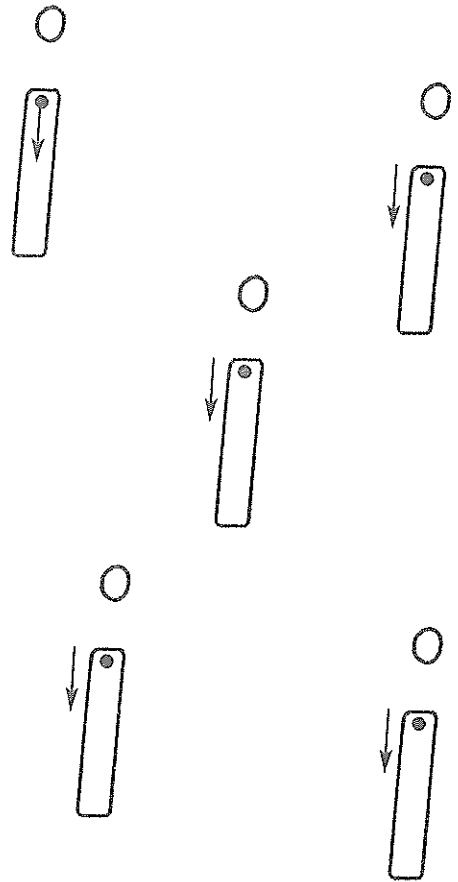
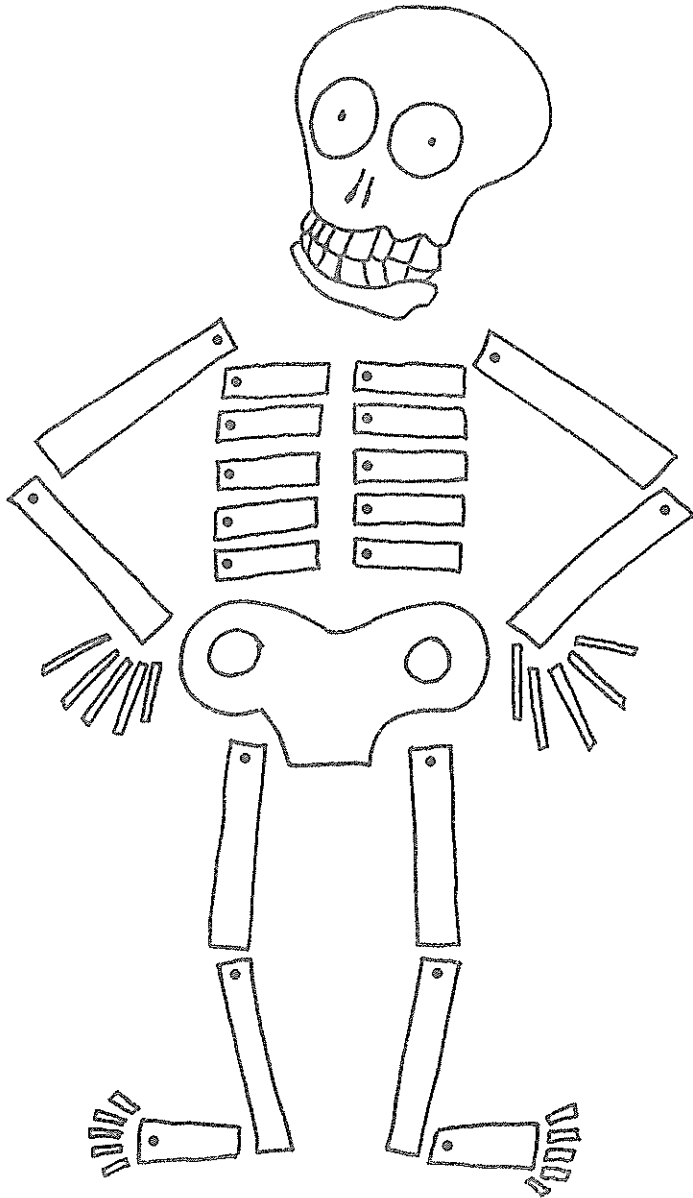
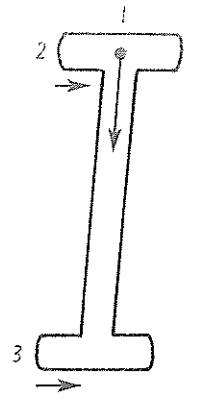
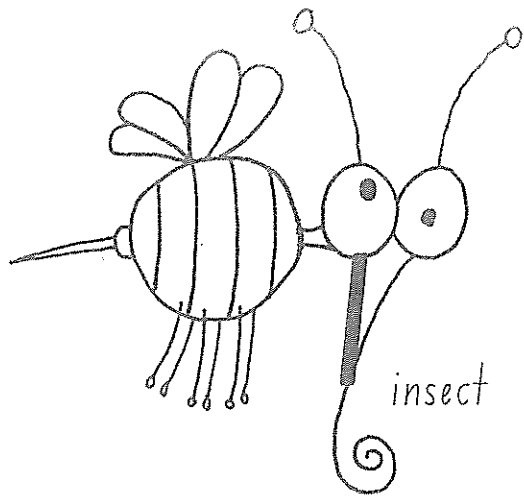
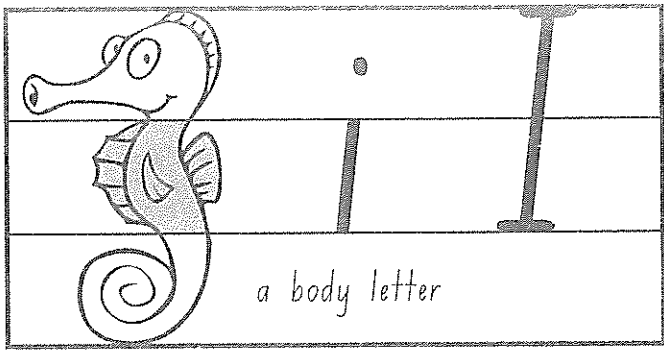

CVC - ä

# Read & Find

Optional

Read each word. Find the picture and color it in. Check off each word as you find it.



- cat
- map
- pan
- bat
- van
- jam
- fan
- bag
- hat
- sad





# WHAT'S THE TIME MR WOLF?

START

12:00

MISS A TURN!

6:00

10:00

1:00

9:00



3:00

1:00



7:00

HAVE ANOTHER TURN



COVER ANY CLOCK

5:00

Teach This...

4:00

8:00

7:00

2:00

6:00

11:00

REMOVE ANOTHER PLAYER'S COUNTER

2 - 4 players

Need: A die and coloured counters for each player

Place your counters on the start line. Take turns rolling the die and moving that number of spaces on the board. When you land on a digital time, match it with the clock in the middle of the board. Place your counter on the clock.

If you can't place your counter, you miss that turn.

Take turns rolling and moving around the board until all the clocks are covered in the middle.

The person with the most clocks covered at the end is the winner!

# Optional

## Color by Addition

- 3 - BROWN
- 4 - GREEN
- 5 - YELLOW
- 6 - RED
- 7 - BLUE
- 8 - PINK
- 9 - BLACK
- 10 - PEACH

\*You can choose any colors for empty spaces..

School Days

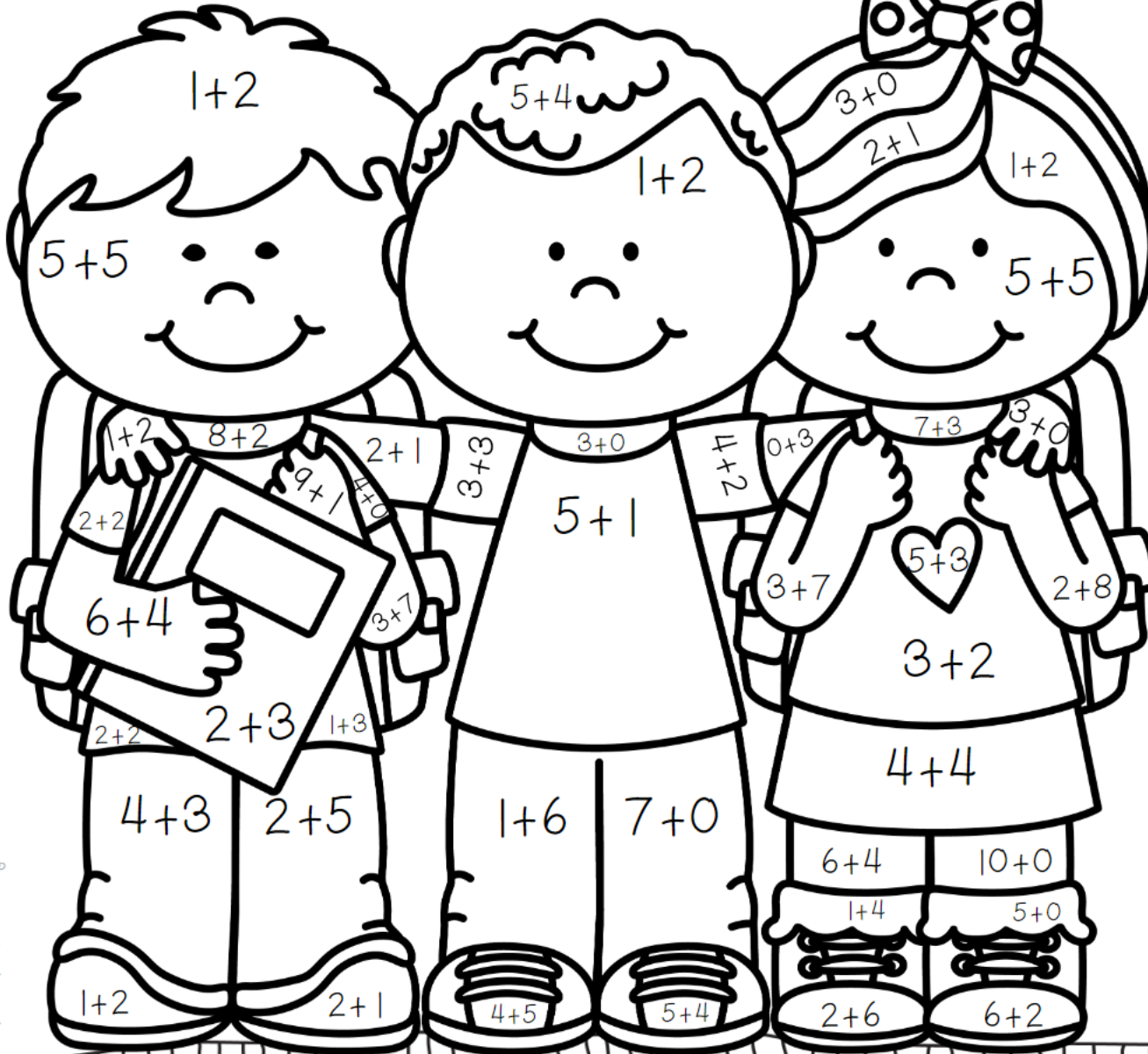

OPTIONAL TASK

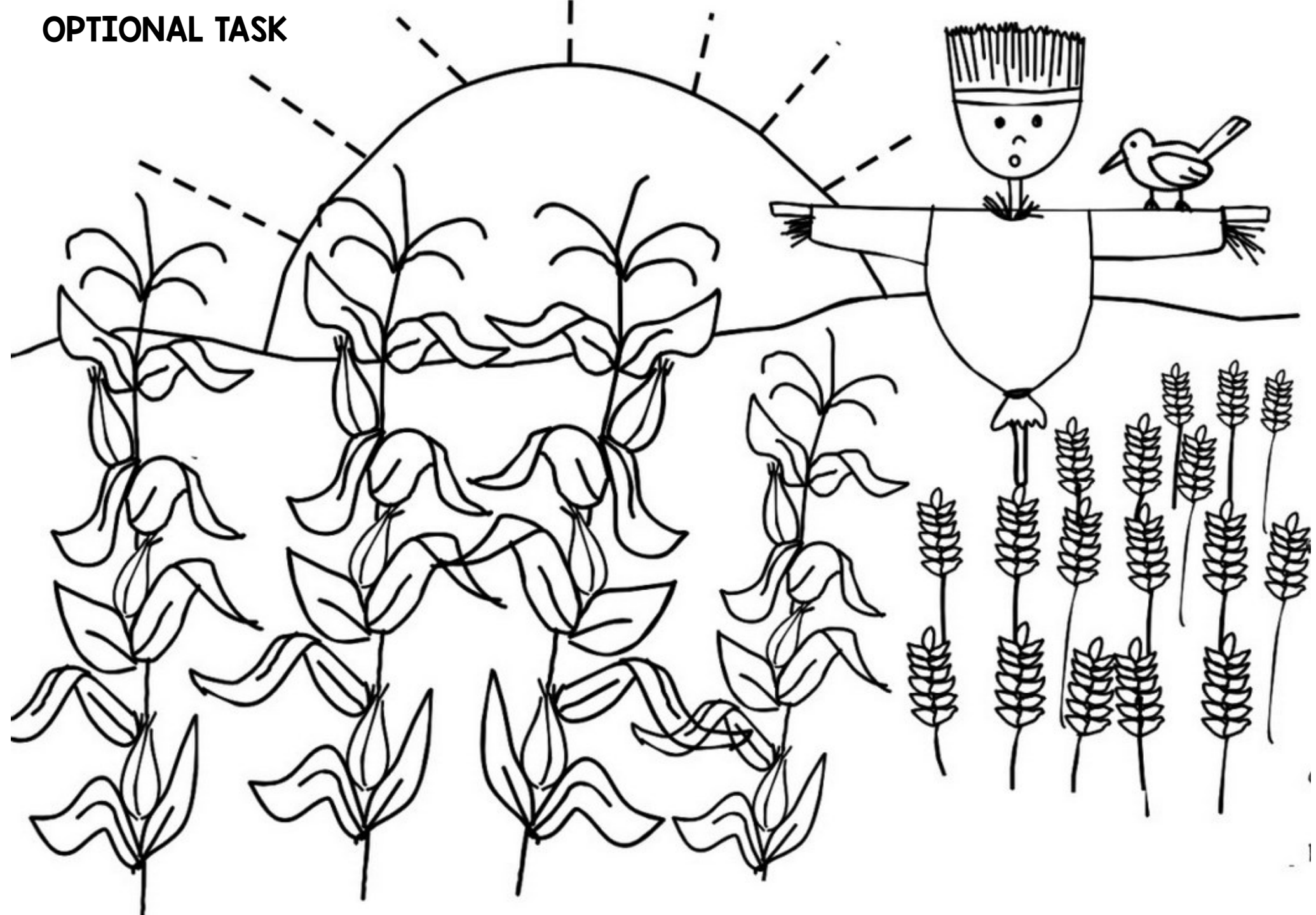



Thursday



# OPTIONAL TASK

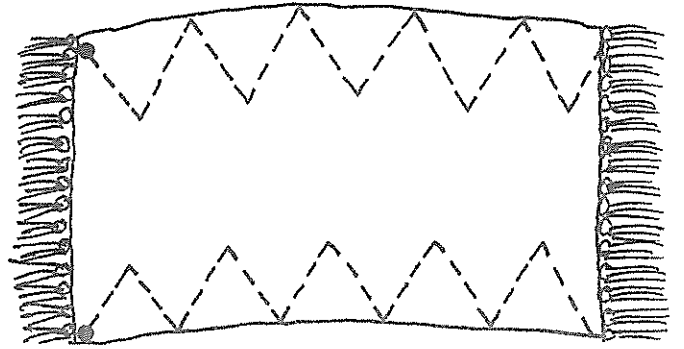
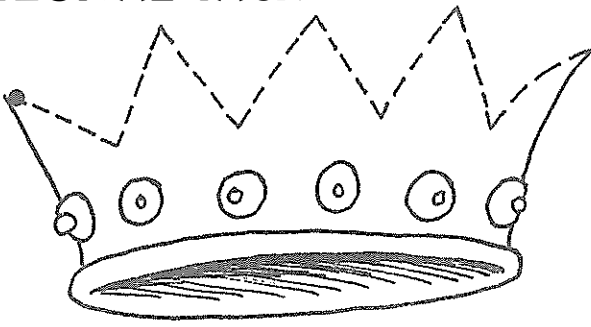
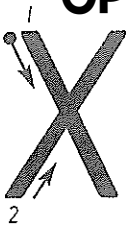

Trace.

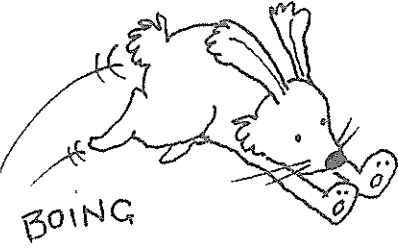

Trace. Find x.

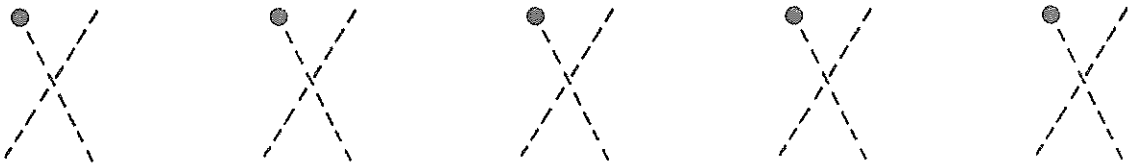
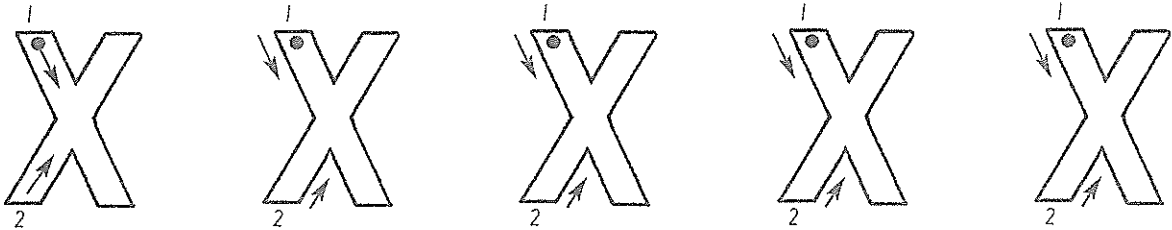
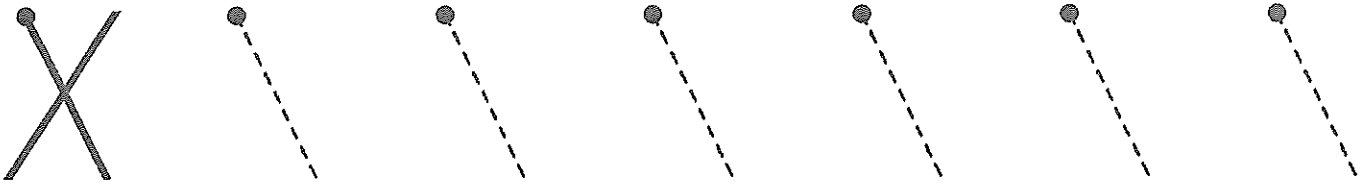

Try your own.



# OPTIONAL TASK

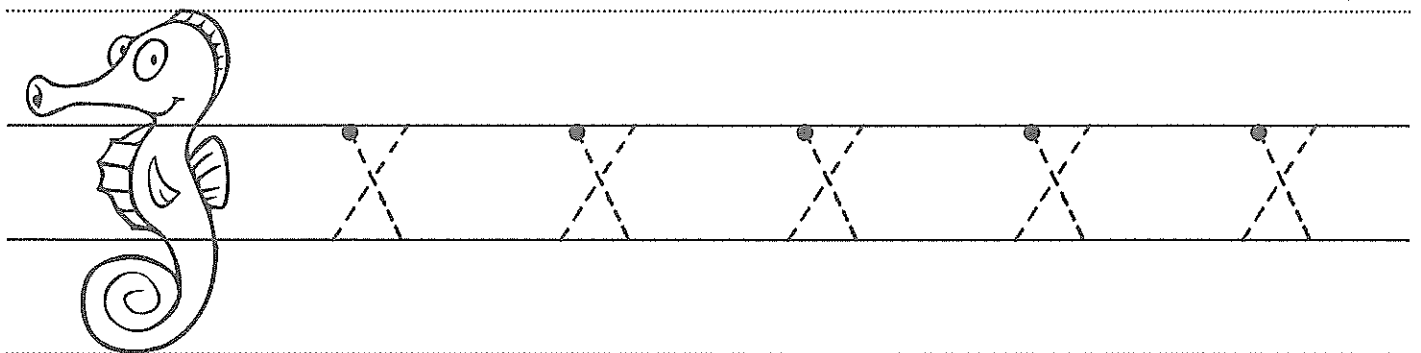
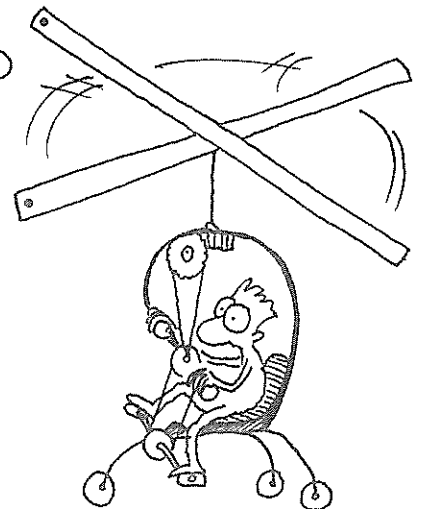
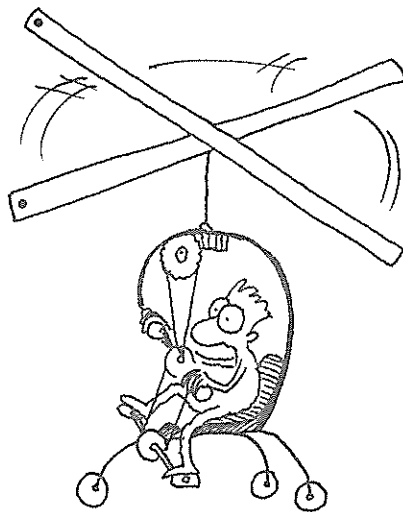
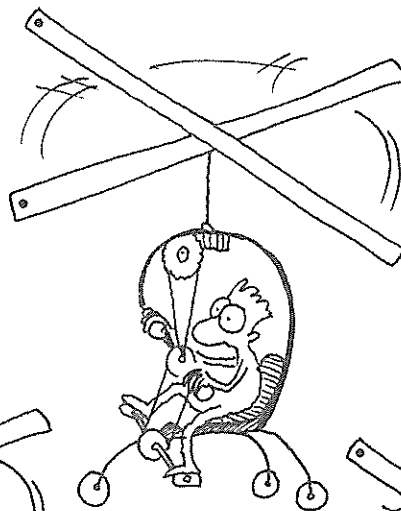
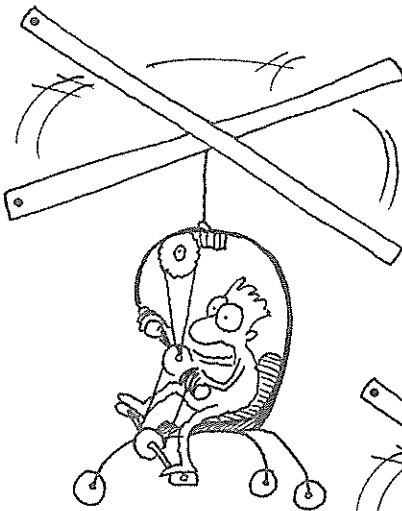
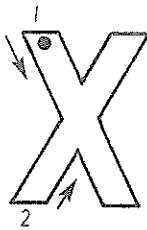
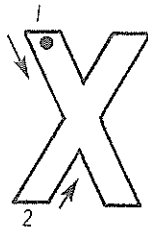
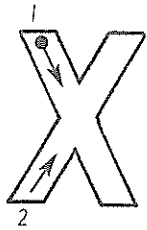
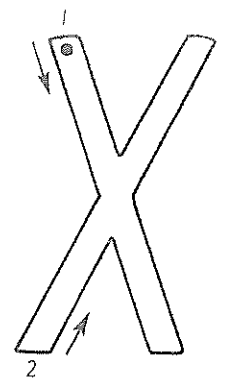
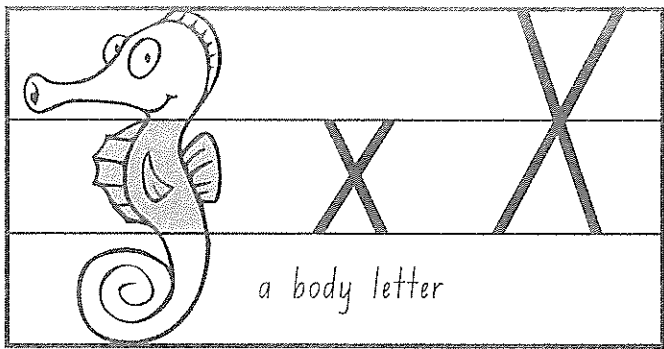

# OPTIONAL TASK

Name: \_\_\_\_\_

Find the words! They all go across.

Word list:

sun



cap



box



pot



pen



nut



dig



bug



pig



rot



m	p	o	t	n	b
v	c	z	b	o	x
d	i	g	l	k	j
h	g	f	n	u	t
d	s	b	u	g	a
c	a	p	p	i	y
t	e	r	r	o	t
w	q	a	p	e	n
s	d	s	u	n	f
h	p	i	g	j	l



Name: \_\_\_\_\_

HOUR



# TICK, TOCK TIME

Cut and paste the clocks next to the correct time!

10:00		9:00	
8:00		12:00	
4:00		2:00	
11:00		5:00	
3:00		7:00	

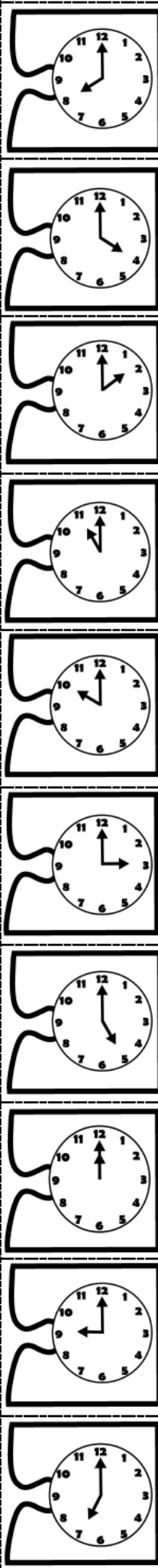

Draw the hands on these clocks to show the time below!

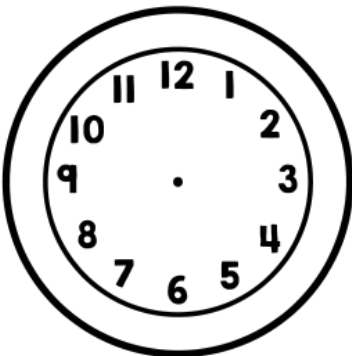

12:00

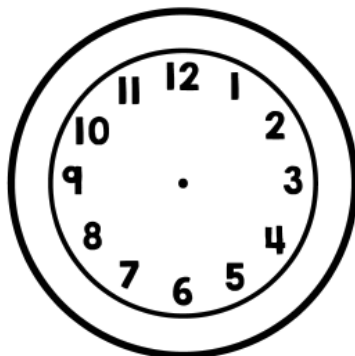

5:00

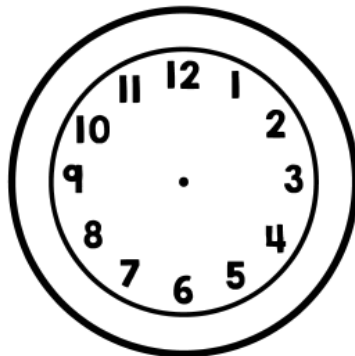

1:00

**This page has been intentionally left blank.**

# OPTIONAL TASK

Addition to 10

Name: \_\_\_\_\_

# Color by Number: Winter

Use the code below to color the picture!

2 two	yellow	3 three	orange	4 four	dark blue
5 five	pink	6 six	light blue	7 seven	gray

© 2020 The Primary Partner | Libby Klinner Teaching LLC

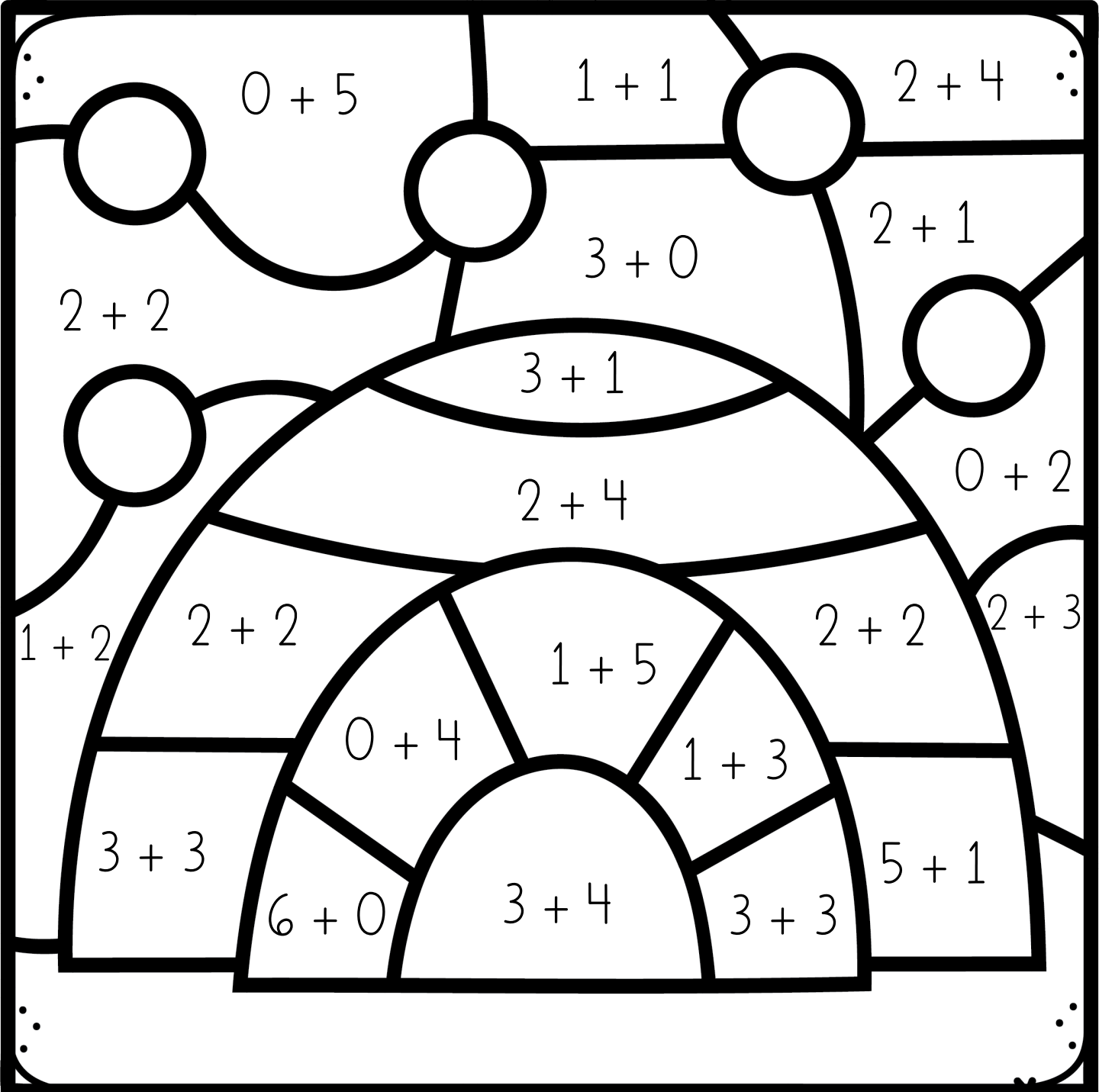



Friday

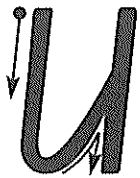

Trace.

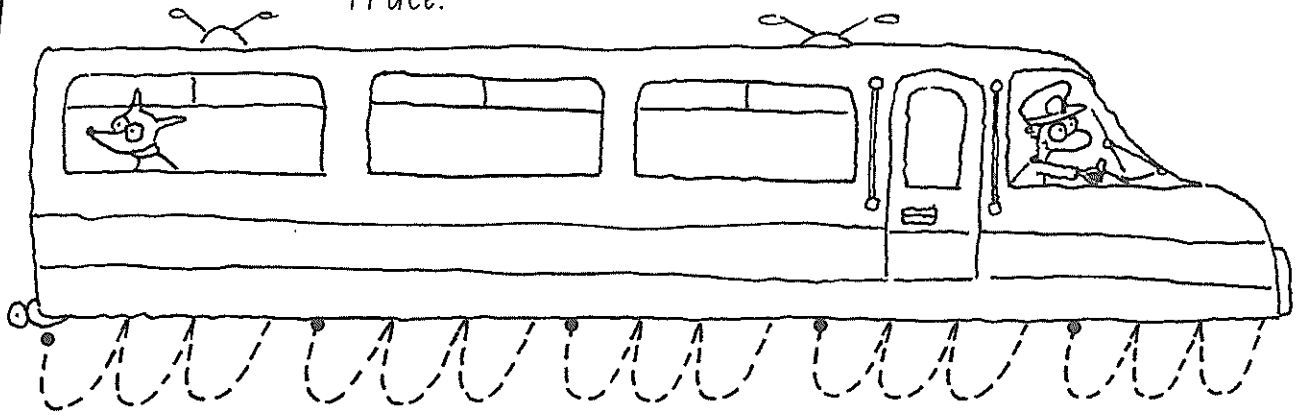

Trace the waves with three different colours.

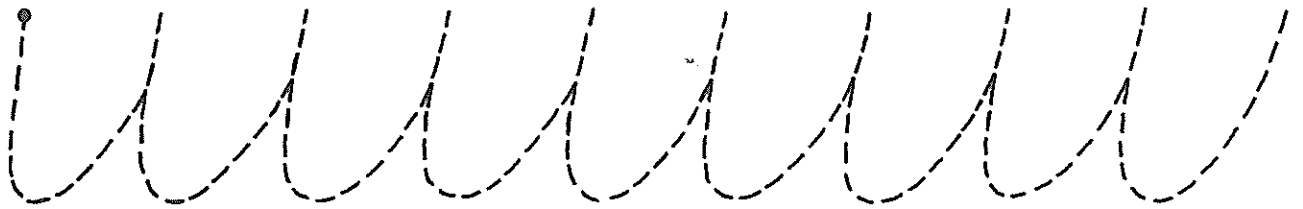

Trace. Find the u's.

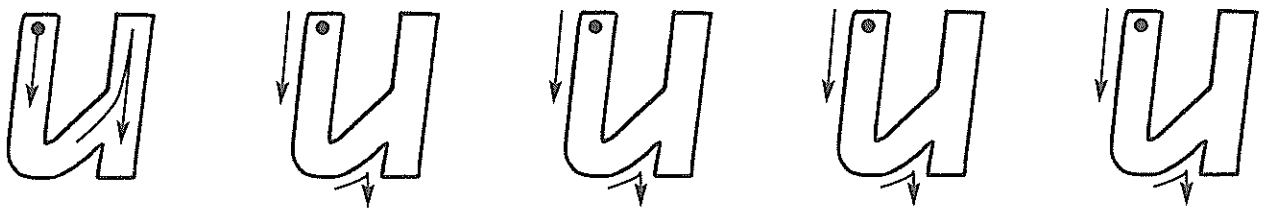

Try your own.



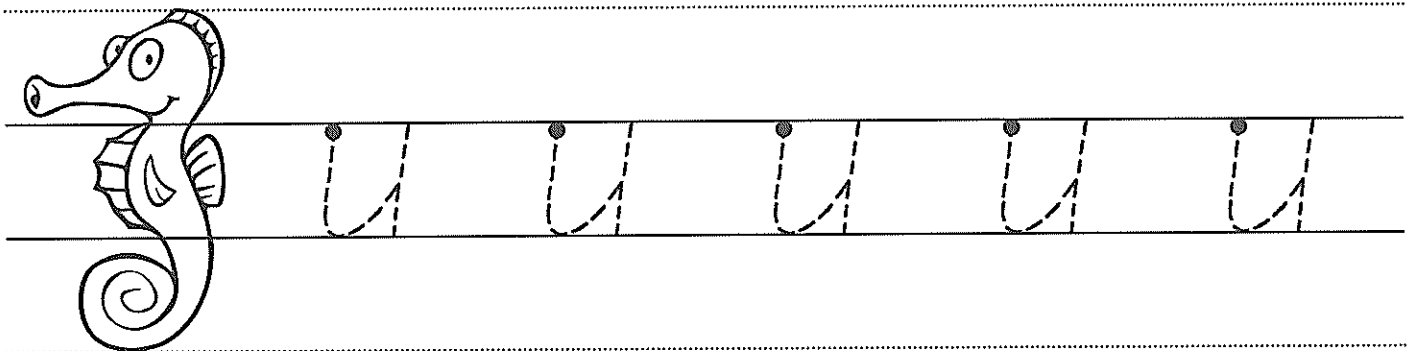
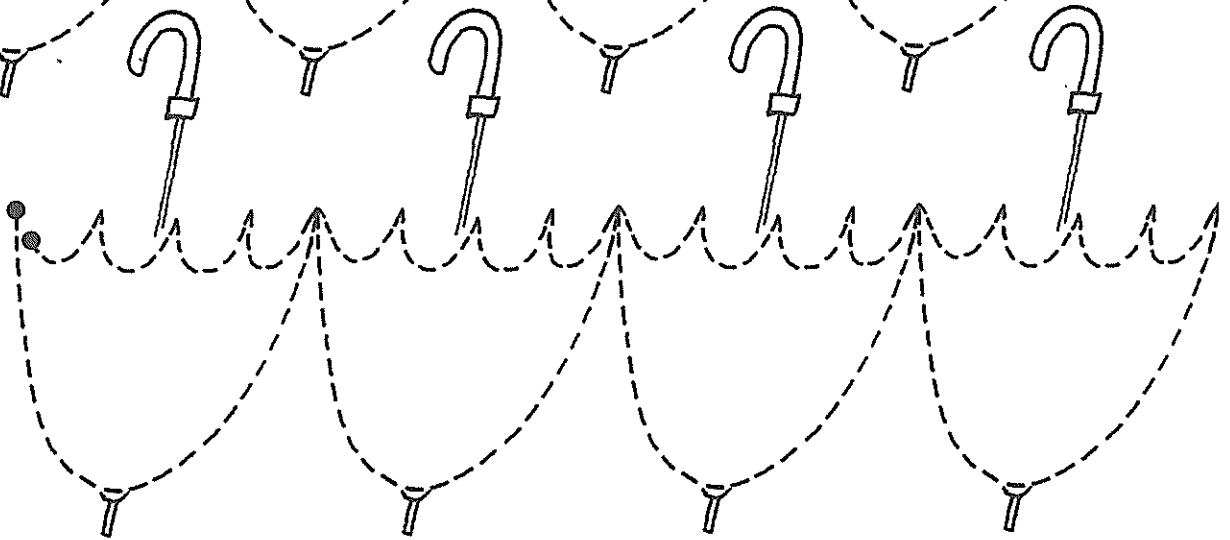
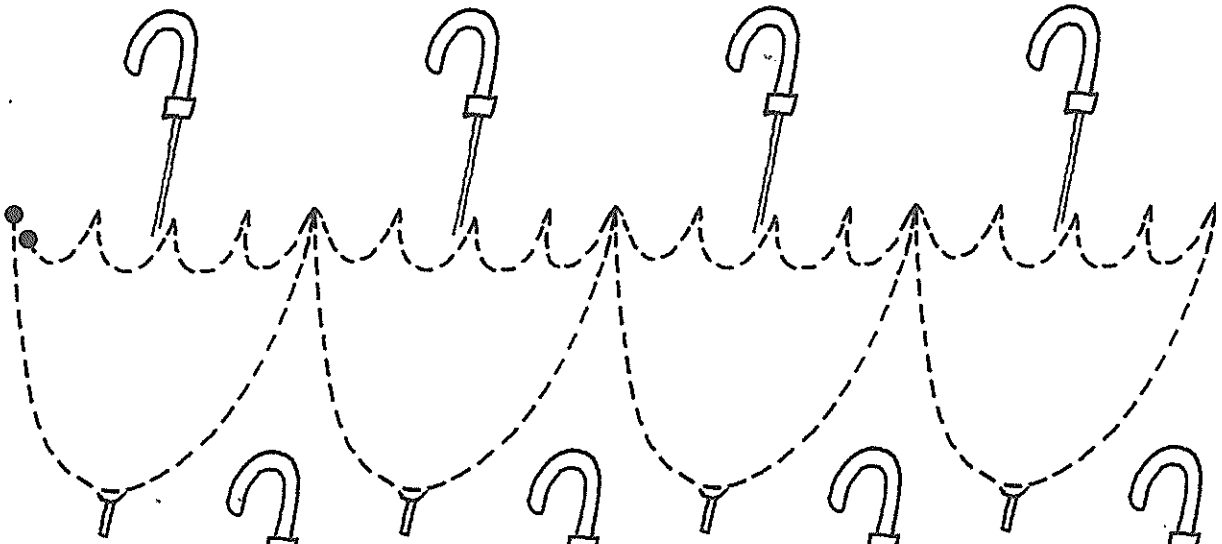
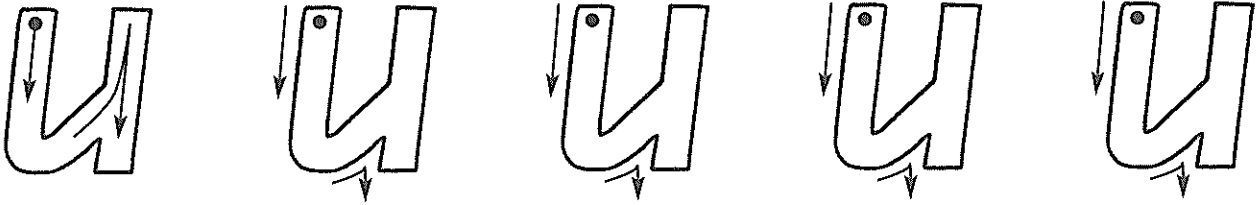
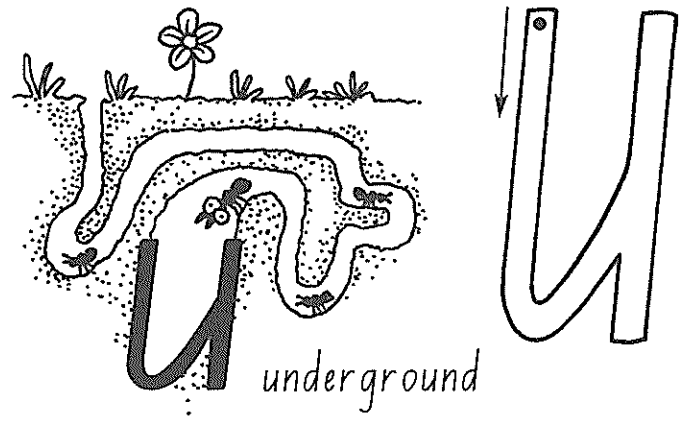
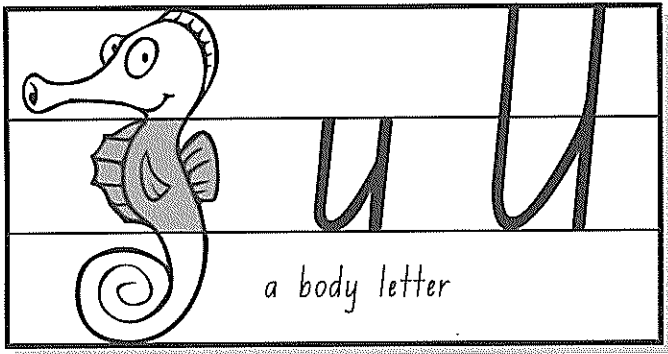

# OPTIONAL TASK

Name: \_\_\_\_\_

Find the words! They all go across.

Word list:

hut



nap



pit



rod



web



pan



mad



gum



bin



win



q	a	z	n	a	p
r	o	d	w	s	e
m	a	d	d	c	r
f	v	t	p	a	n
g	b	i	n	b	y
w	i	n	h	n	u
j	m	p	i	t	i
k	g	u	m	o	l
p	q	w	e	b	a
h	u	t	z	d	c



# Telling Time 1

Melissa Mouse is learning how to read a clock. Help her match the times to the clocks by circling the clock that shows the time written on the left.

12:00

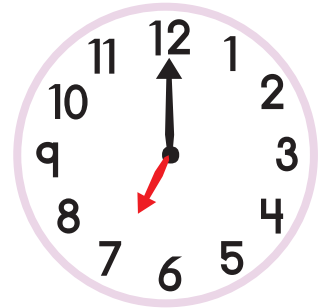
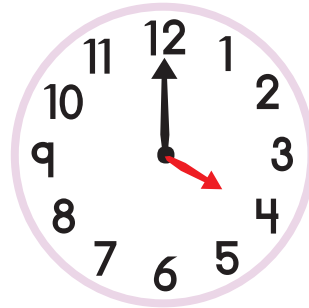
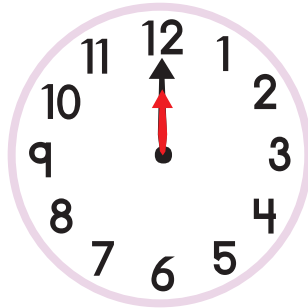

8:00

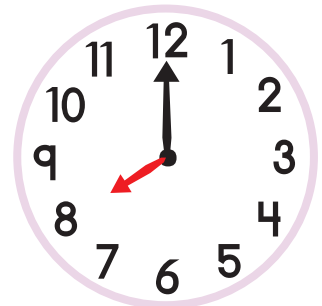
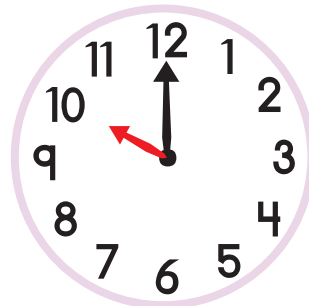
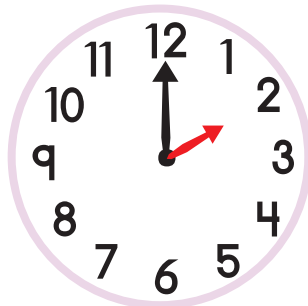

3:00

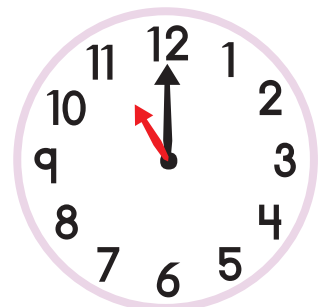
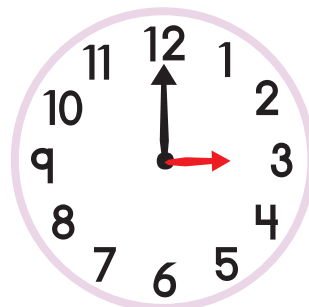
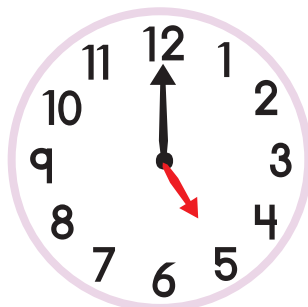

Melissa needs to be home for her supper by 5:00. Underline the clock that shows 5:00.

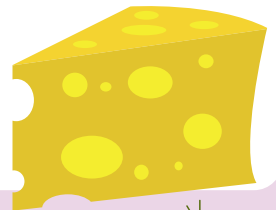



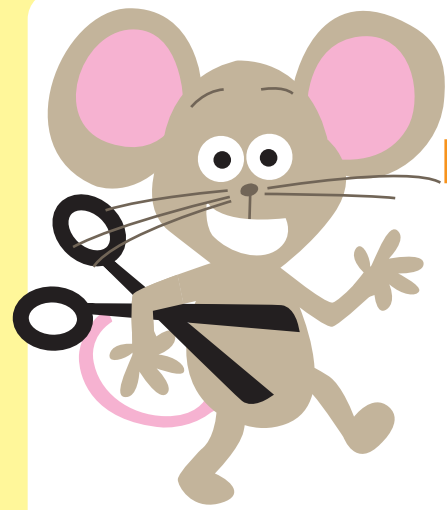

# Telling Time 3

Melissa Mouse is learning how to read a clock. Will you help her match the times to the clocks?

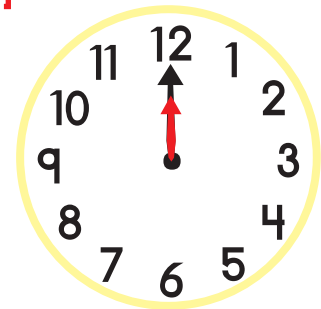
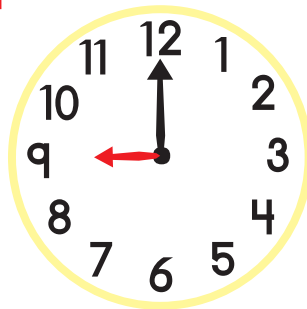
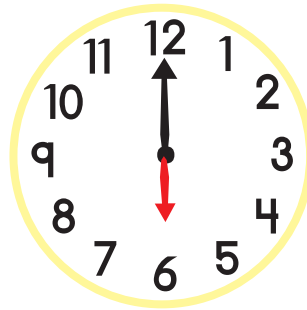
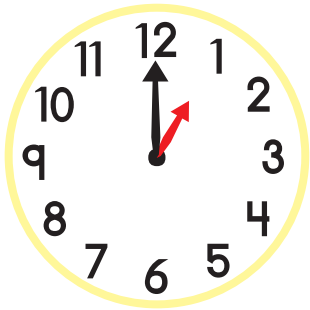

Cut out the times below and glue them under the correct clocks.

9:00

12:00

6:00

1:00



**This page has been intentionally left blank.**

# OPTIONAL TASK

Name: \_\_\_\_\_

Adding to 10



## Color by Addition

- |            |            |            |
|------------|------------|------------|
| 2 - RED    | 5 - BROWN  | 8 - BLUE   |
| 3 - PURPLE | 6 - ORANGE | 9 - BLACK  |
| 4 - YELLOW | 7 - GREEN  | 10 - PEACH |
- \*YOU CAN CHOOSE COLORS FOR ANY EMPTY SPACES

## School is in Session!



# Group Celebrations

Draw a picture of your group celebrating this event.

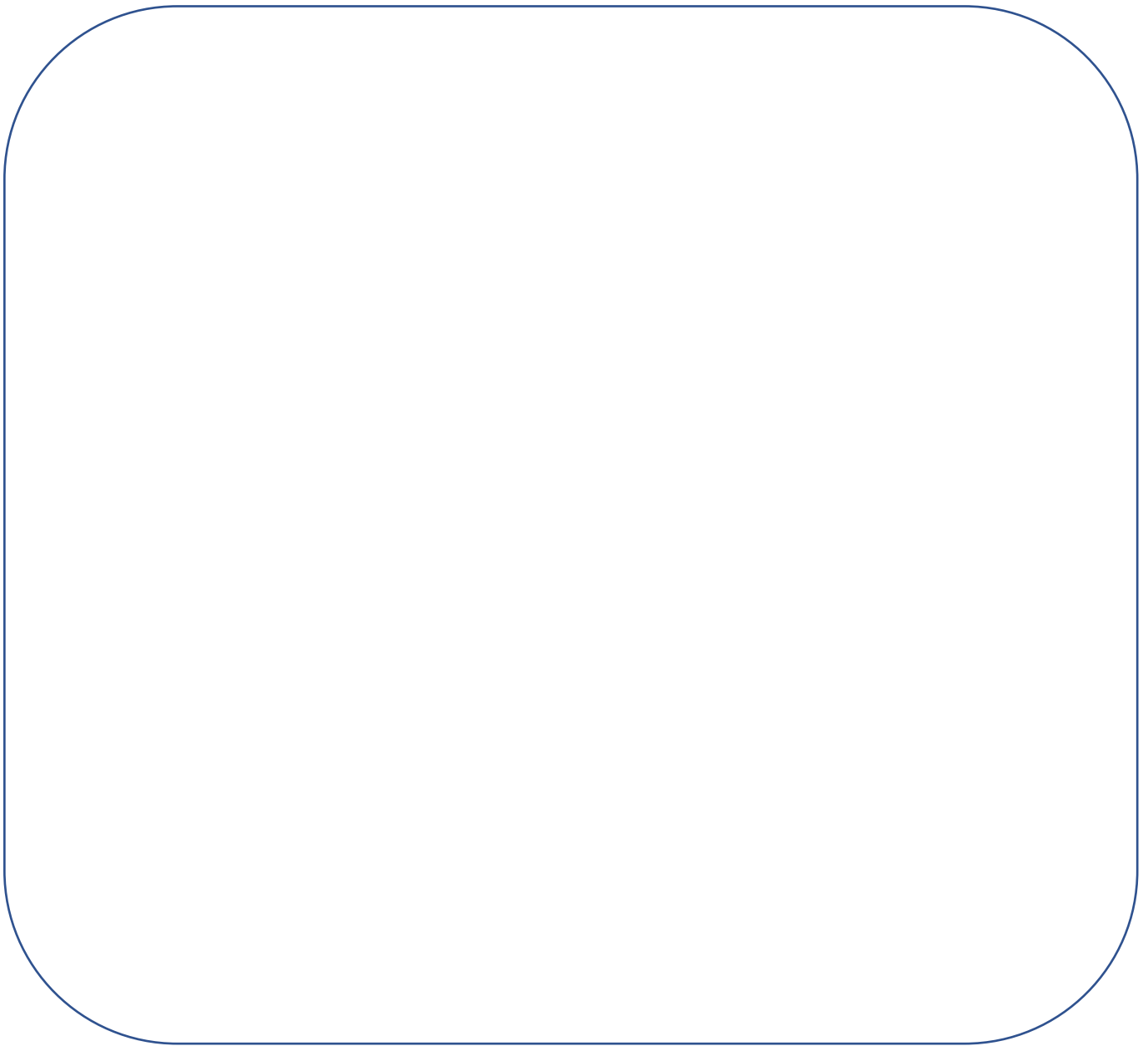

Describe how you felt participating in this celebration.

---

---

---

---

---

# **Extra Resources**

**Tricky Words - practise your list on Monday, Wednesday and Friday.**

**Decodable Words - choose some of these words to practise on Tuesday and Thursday.**

**Word Work Ideas - some fun ways to practise these words.**

**Jolly Phonics Card - to help when writing independent sentences.**

Tricky Words

List 1

I to

the do

was of

Tricky Words

List 2

he we

she be

me

Tricky Words

List 3

are you

all your

here

Tricky Words

List 4

come there

some they

said

Tricky Words

List 5

go

my

no

one

so

Tricky Words

List 6

by

like

only

have

old



*Tricky Words*

*List 7*

*live down*

*give what*

*little*

*Tricky Words*

*List 8*

*when who*

*why which*

*where*

Tricky Words

List 9

any before  
many other  
more

Tricky Words

List 10

were saw  
because could  
want

Tricky Words

List 11

should two

would four

right

Tricky Words

List 12

goes their

does

made

Tricky Words

List 13

always every

after also

cover once

Tricky Words

List 14

brother eight

mother upon

love

# DECODABLE WORDS- 3 SOUNDS (NO DIGRAPHS)

sat	pin	sip	pip
pat	sit	tap	pit
pan	tip	tin	tan
gig	gag	gap	man
mat	map	gas	tag
pig	nag	sag	nap
nip	nit	top	bus
cot	hid	cog	rib
pop	rap	pal	lip
dad	hop	bad	bib
bit	ram	rug	hat
dip	dim	din	did
got	dig	rip	not
dot	dog	bat	hog
log	dug	lap	rat
hut	big	lad	rot
ham	hop	sum	tub
him	sub	cub	but

# DECODABLE WORDS- 3 SOUNDS (NO DIGRAPHS)

pit	hot	hug	mud
had	lot	bud	bug
cab	pot	bin	can
cop	cap	cat	tub
bag	bat	hum	run
mug	mum	sun	rim
rag	hit	bun	mop
gum	nut	cob	lit
zip	jam	yet	yes
van	kid	kit	get
yum	beg	met	pet
pen	peg	pen	men
kin	vet	zap	wet
ten	fin	jig	red
jet	fun	bet	fit
fig	fog	leg	jog
fat	vat	win	jug

## DECODABLE WORDS- 2 SOUNDS

at	in	it	am
on	if	up	us

## DECODABLE WORDS- 4 SOUNDS (NO DIGRAPHS)

pips	spin	pigs	spat
pans	camp	bolt	cost
slug	stop	clip	drum
mist	slid	lost	plum
blob	slap	trap	brag
smog	suds	tram	club
hand	sand	band	snap
blab	glum	crab	bond
belt	flag	swim	tent
went	nest	best	zest
test	swum	bend	bent
swim	swam	jump	west

## DECODABLE WORDS- 3 SOUNDS (INC DIGRAPHS)

mess	fizz	kiss	hill
bell	puff	doll	tell
duck	pack	neck	kick
sick	rock	chip	shop
chess	shed	fish	dish
dash	hush	shell	shut
whip	when	then	that
moth	wish	this	chick
quack	quit	bang	sing
rang	long	king	ring
boil	coin	join	soil
tail	pain	sail	wait
loud	sour	noun	pout
boat	moan	soap	goat
blue	glue	clue	true
reel	feed	seen	meet
boot	room	loot	food
card	mark	star	park



# DECODABLE WORDS- 4 SOUNDS (INC DIGRAPHS)

swell	skull	cliff	drill
sniff	fluff	troll	press
dress	frizz	block	stick
flock	trick	click	truck
smell	floss	stuff	stuck
bench	chest	punch	lunch
brush	trash	shrub	thump
whisk	cloth	quest	squish
swing	quilt	sting	brain
again	snail	drain	trail
float	toast	bloat	throat
flies	tries	cried	spies
sleep	green	creek	sweep
shorts	horns	forks	stork
stool	books	scoop	broom
cloud	about	found	count
point	spoil	avoid	coins
perch	germs	river	otter
start	smart	farms	scarf

# DECODABLE WORDS- 5 SOUNDS (INC DIGRAPHS)

stomp	clamp	spring	stress
asleep	rabbit	kitten	gifts
crabs	melts	racket	frogs
bucket	kennel	print	sudden
spills	across	attacks	comic
strap	begin	plains	carrot
jacket	frost	lesson	thinks
stuffs	forgot	grunt	bottom
stings	groans	panic	getting
happen	grabs	slept	swings
magpie	brings	spent	chicken
muffin	butter	balloon	winter
sprint	seven	drench	rescue
wooden	clouds	garden	vanish
afford	finish	factor	cannot
shivers	sister	snarls	puppet
ground	visit	unload	exact

# DECODABLE WORDS- 6+ SOUNDS (INC DIGRAPHS)

presents	helpless	numbat	rockets
cricket	camping	helmet	protect
transport	insect	sunscreen	stands
replies	popcorn	pumpkin	raincoat
piglet	sailing	mattress	collect
missing	important	speeding	platform
unfold	himself	difficult	sprains
happening	biggest	sunset	morning
soaking	stocking	fingernail	mailbox
mountain	helicopter	labrador	problem
entertain	continued	second	understand
hundred	thousand	mandarin	consistent
expected	interest	bedroom	invent
problem	different	shopping	replied
explain	herself	monster	crimson
munching	another	destroy	bringing
against	children	reading	paintbrush

# WORD WORK IDEAS

<p><b>BLOCK WORDS</b> Write or stick letters onto blocks, then use them to build your words.</p>	<p><b>FANCY WRITING</b> Write your words in fancy writing e.g. twirly writing, bubble writing, dotted, squiggle writing.</p>	<p><b>BEAD WORDS</b> Write letters on beads and then thread your words onto string or pipe cleaners.</p>	<p><b>SENSORY WRITING</b> Write your words in a tray of rice, sand, salt or sugar.</p>
<p><b>ALPHABETICAL ORDER</b> Write your words in alphabetical order. Challenge- write them in reverse alphabetical order.</p>	<p><b>DOT PAINT WORDS</b> Use a cotton bud or a paint brush to write your words by dotting each letter.</p>	<p><b>LETTER COLLAGE</b> Cut out letters from newspapers and magazines and create your words.</p>	<p><b>TRAIN TRACKS</b> Write your words on stickers and place on your train set. Say the words as the train rolls over them.</p>
<p><b>MAGNETIC LETTERS.</b> Make your words with magnetic letters.</p>	<p><b>PLAYDOUGH</b> Make your words with playdough.</p>	<p><b>LEGO WORDS</b> Make your words using pieces of lego to build each letter</p>	<p><b>CHALK TALK</b> Write your words with chalk on an outside area or chalkboard.</p>
<p><b>SECRET CODE</b> Create a code with pictures for each letter of the alphabet. Write your words in that code.</p>	<p><b>WRITING TOOLS</b> Use as many different writing tools as you can to write your words e.g. pencil, crayon, texta, marker</p>	<p><b>RAINBOW WRITE</b> Write your words with different colours. You might like to use different colours for each word, or each letter.</p>	<p><b>WORD REVEAL</b> Write your words with white crayon, then use watercolour paint or textas to reveal your words.</p>
<p><b>BEADS &amp; BUTTONS</b> Use small objects (like beads, buttons, gems) to make your words.</p>	<p><b>PAPER WORDS</b> Tear up paper into little pieces then glue together to make your words.</p>	<p><b>STICKER WORDS</b> Use small dot stickers or any other small stickers to make your words.</p>	<p><b>MESSY WORDS</b> Use messy materials like slime or shaving cream to write your words in!</p>
<p><b>MAKE A PUZZLE</b> Write your words and then cut them up into a puzzle. Then put back together.</p>	<p><b>FIND A WORD</b> Make a find a word with your sight words.</p>	<p><b>MEMORY/SNAP</b> Write your words twice onto flash cards. Use to play Memory or Snap.</p>	<p><b>BINGO</b> Write your words onto Bingo boards and make some flash cards. Use to play Bingo.</p>
<p><b>TARGET PRACTICE</b> Put your words onto targets and try to hit them with a ball or beanbag.</p>	<p><b>SKITTLES</b> Put your words onto skittles and say the word as you knock them over.</p>	<p><b>HIDDEN PICTURES</b> Draw a picture and hide your words inside the picture.</p>	<p><b>WRONG HAND</b> Write your words with your non writing hand.</p>

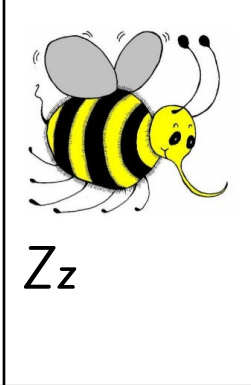
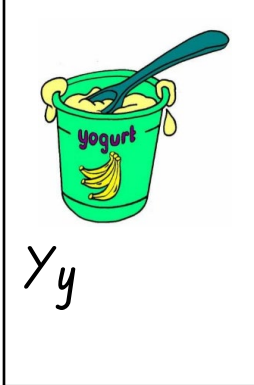
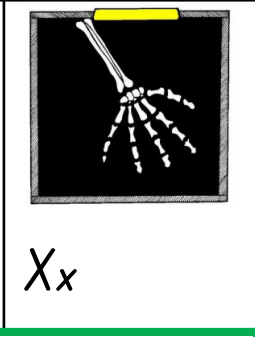
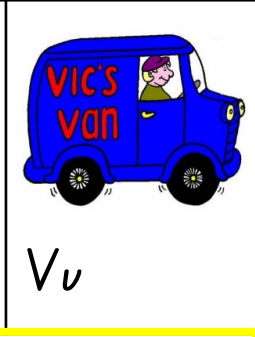
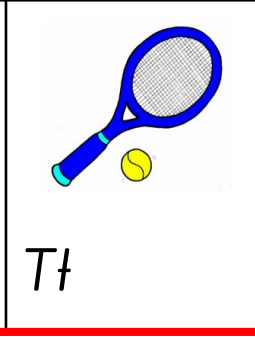
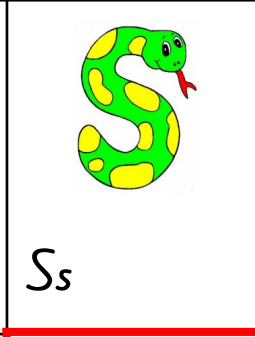
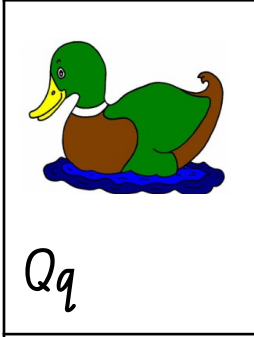
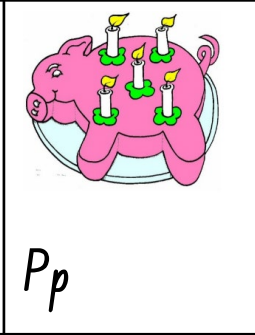
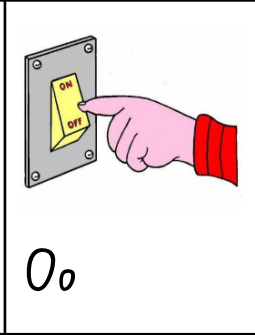
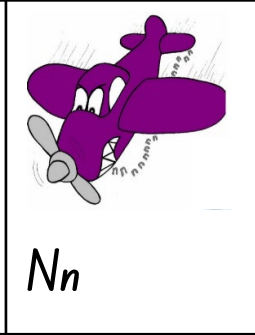
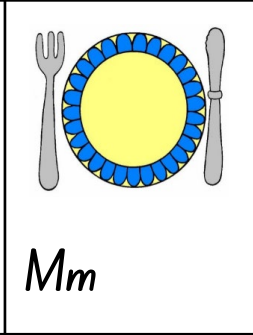
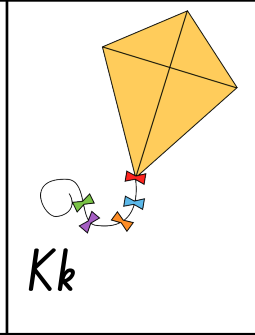
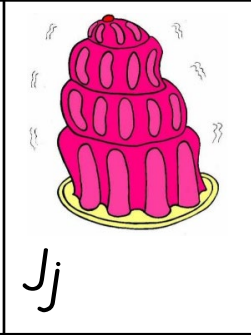
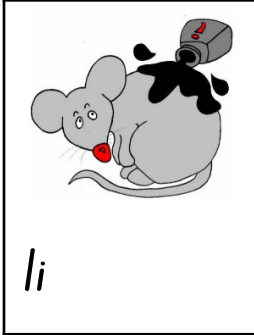
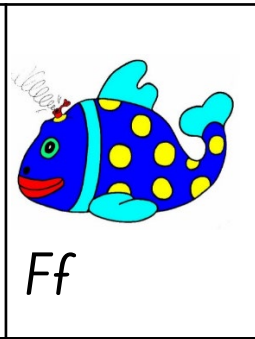
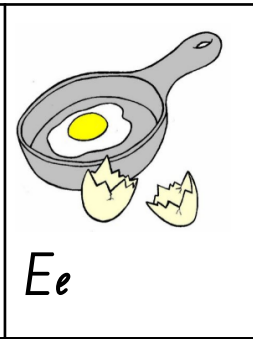
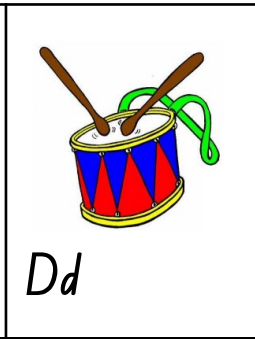
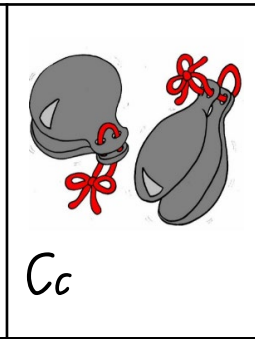
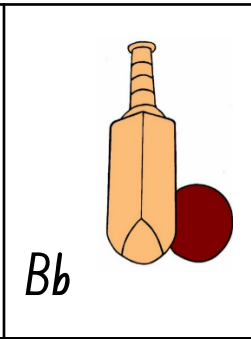
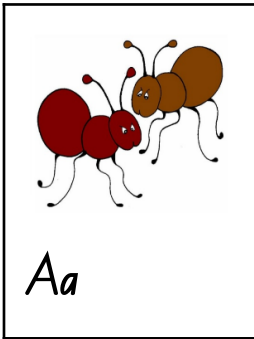

Red Tricky Words

I	me	to
the	we	do
he	be	of
she	was	

Yellow Tricky Words

are	come	there
all	some	they
you	said	
your	here	

Green Tricky Words

go	by	live	when
no	only	give	why
so	old	little	where
my	like	down	who
one	have	what	which

ai



oa

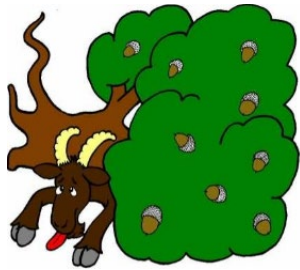

ie



ee

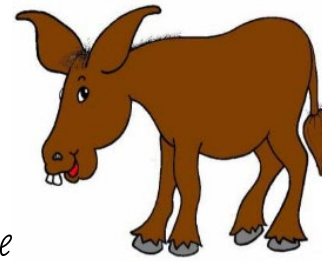

or

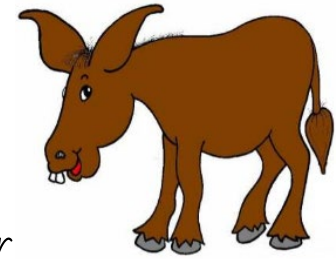

ng



oo



oo

ch



sh



th

th



qu

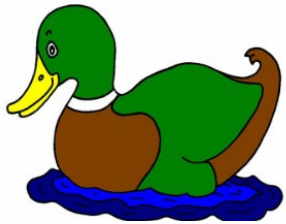

ou

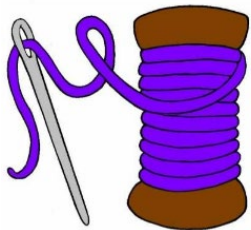

oi

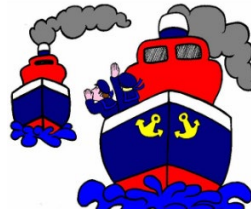

ue



er



ar

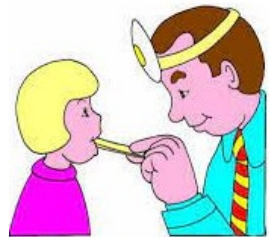

### Blue Tricky Words

any  
many  
more  
before

other  
were  
because  
want

saw  
could  
should  
would

right  
two  
four  
goes

does  
made  
their

